

Series 7250



Product Manual

CONTINUOUS LEVEL CONTROLS

7250 Series HR Digital Stik



**ABSOLUTE PROCESS CONTROL
KNOW WHERE YOU ARE... REGARDLESS**

7250 Series Manual

Overview

This document explains the basic hardware interface requirements, operating characteristics and describes the software protocols for the 7250 series HR Digital Stik. In addition, the dimension and installation drawings, part number sequence and agency approvals have been included in the back of this document. It is important to note that the standard product is intrinsically safe and any device, controller, or radio connected to this product must have a barrier designed to meet the entity parameters and special requirements indicated in the installation drawing E0241200 (page 6).

Electrical Interface

Signal Descriptions

The 7250 requires only three wires for its power and interface connections, Power, Data, and Ground. On the Stainless Steel housing models, the cable shield or “Shield” pin in the 4 pin connector, is connected to the steel housing and must be connected to earth ground.

Power Supply

The supply voltage to the probe “Power” is typically +5VDC but can range from 3.7VDC to 7.93VDC. The main power supply in the 7250 is not a “switching” design, so running it at a higher voltage does not reduce the input current draw.

Data Signal

The “Data” signal is an “open-drain” type signal and is used for the bidirectional half duplex asynchronous serial communications. Any device connected to the probe must be of an “open-drain” type signal and must not be driven to a high logic level. Because this data signal may be driven by either the master or any slave device, a single pull up resistor of typically 1k Ω should be the only element that establishes the high logic level voltage. Also, because of this scheme, there could be multiple master or slave devices connected together.

The logic level voltage thresholds are similar to TTL levels and a pull-up resistor must be included in the user’s interface circuitry. This signal is clamped internally by the 7250 with a +5V TVS

device. The inactive or “idle” state is at a “high” logic level.

Ground

The “Ground” connection is the common return path for both “power” and “data”.

Intrinsically Safe Connections

The 7250 is an intrinsically safe device and therefore, when used in an intrinsically safe installation or application, must be connected to an apparatus that limits the power, voltage, and current to the 7250 in accordance to the entity parameters specified. Reference the installation drawing E0241200 (page 6) for more details.

Operation

The 7250 runs continuously once power is applied to it. When connected to a battery powered device (typically a wireless radio), power is supplied for a short duration of time, long enough to collect the required amount of data, then power is switched off to the probe in an effort to reduce the power draw and conserve battery life. If power is applied to the 7250 on a continuous basis, it will continue to take level and temperature readings and communicate the data through the asynchronous serial communications signal.

Power Consumption

The 7250 draws roughly 10mA of current when it is not taking temperature measurements and roughly 12mA of current when it is taking temperature measurements (with 5 temperature sensors). Figure 1 shows the current draw of a model 7252 which takes the temperature readings in the beginning (approximately 700mS) and also takes 25 product and 1 interface (water) reading at 100mS per reading. As seen in the chart, this is represented by the 700mS high level followed by the 2 second lower reading. The signal in the screen capture is a voltage reading taken across a 10 ohm resistor in series with the power supply input. The scale for this reading is 1mA per minor division and 5mA per major division.

Software Protocol

There are several different product numbers available for the 7250 Series of probes. The ‘x’ in the part number 725x identifies the data protocol. The electrical interface remains the same, regardless of the software protocol specified by the model number.

There are currently two different software protocol versions available (7252 and 7255). In actuality, the 'protocols' are very similar. The significant difference is the amount of product measurements transmitted within the data string. A unique start character is also sent at the beginning of each data string to identify the data string type, or hence, the 'protocol'.

Communication Parameters (fixed)

baud 9600
 parity odd
 data bits 7
 start bits 1
 stop bits 1

Data Format

The data string is in **ASCII** format and the total data string transmission time is roughly one (1) second for the 7255 and three (3) seconds for the 7252.

Approximately 100ms after power up, a start character (“=” for 7252, “<” for 7255) is transmitted and the first product position is measured and transmitted. Subsequent position measurements and transmissions continue every 100ms until the complete number of products has been transmitted. One interface position is transmitted immediately following the final product position. All temperature data is then transmitted along with a final 2-digit ASCII Checksum followed by a Carriage Return character to end the string. Note that a comma character (’,’) is transmitted between each position and temperature measurement (see example below).

The probe will continue to take level and temperature readings and the data string transmission process continues repeatedly as long as power is applied to the probe.

The data string length is protocol dependent (i.e. 269 bytes for 7252; 134 bytes for 7255). The data string is comprised of a start character, product levels (protocol dependent: 25 for 7252; 10 for 7255), 1 interface level, and 5 temperature sensor levels followed by a 2-digit ASCII Checksum and a carriage return character (<CR>).

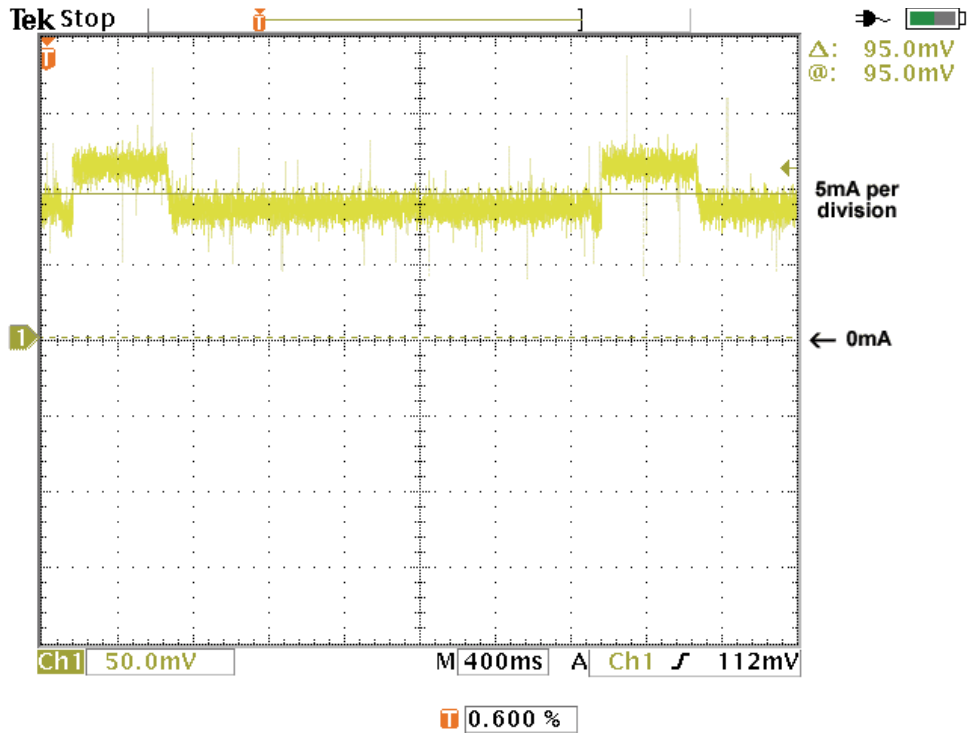

Fig. 1 Power Consumption

For probes ordered with only 1 temperature sensor (i.e. T1 or R1), the temperature reading value of that one sensor is placed in all five temperature data locations in the string.

NOTE: Data values outside the ranges specified above indicate an error condition.

Data String	
s,ppp.pppp,ppp.pppp,... ...,ppp.pppp,iii.iiii,+/-tt.t,...,+/-tt.t,CC<cr>	
s:	Start Character (identifies protocol, type and quantity of following data)
ppp.pppp:	Product (000.0000" to 600.0000")
iii.iiii:	Interface (000.0000" to 600.0000") (Note: Interface = 000.0000 if Stik is ordered with only 1 float)
+/-tt.t:	Temperature (-40.0°C to +85.0°C)
CC:	2 digit ASCII checksum (see calculation process below)
<CR>:	End of data string - carriage return

A value of “999.9999” will be transmitted if there is an error in the product or interface levels. A value of “-99.9” will be transmitted if there is an error in the temperature sensor level.

Calculation of Checksum:

All the ASCII characters (from and including the start character to and including the comma (',' after the final temperature digit) in the data string are added together. From this number, the least significant byte is used for the checksum value and is transmitted in its equivalent ASCII characters. Note that capital letters **MUST** be used for the upper hex values (i.e. 'A', 'B', 'C', 'D', 'E', 'F').

For example:

If the checksum value was 0xA5 (hex); An ASCII 'A' and a '5' characters would be transmitted to indicate the checksum value (i.e. 0x41 and 0x35.....the ASCII characters for 'A' and '5').

Data Transmission Example

The following example represents the data transmitted from a 7255 HR Digital Stik (i.e. 10 product levels) which has a full transmission data string length of 134 bytes. Bytes 0 – 130 are used to compute the checksum:

NOTE: The Level values used in the following chart may not be representative of a real life application. The data provided is for example purposes only.

Byte #s	ASCII Chr String	Level Name
0-1	<	Start Character
2-10	123.4567,	Product 1
11-19	456.7890,	Product 2
20-28	654.3212,	Product 3
29-37	987.6543,	Product 4
38-46	124.5789,	Product 5
47-55	234.5678,	Product 6
56-64	267.4310,	Product 7
65-73	478.2354,	Product 8
74-82	752.6143,	Product 9
83-91	891.4578,	Product 10
92-100	002.5389,	Interface 1
101-106	+22.1,	Temperature 1
107-112	+22.3,	Temperature 2
113-118	+22.5,	Temperature 3
119-124	+22.3,	Temperature 4
125-130	+22.1,	Temperature 5
131-132	CC	2-digit ASCII Checksum
133	<cr>	Carriage Return

NOTE: To determine the actual location of a temperature sensor, refer to the Thermometer Spacing tables on Drawing D0246600, sheet 2 of 2, included on page 9 of this manual.

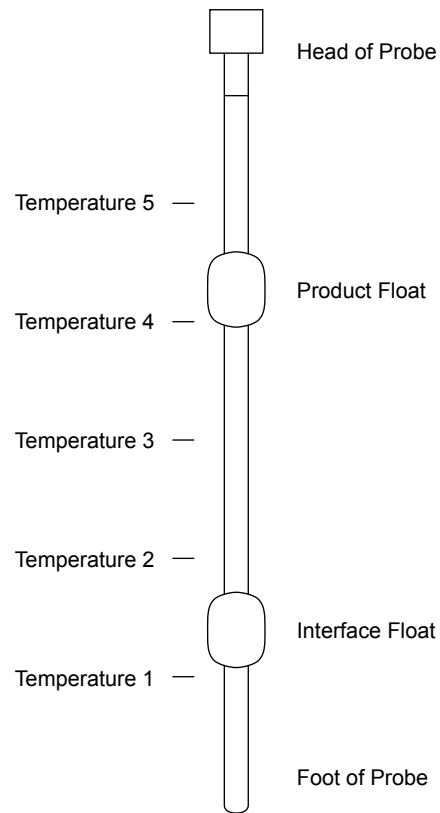

Fig. 2 Temperature Sensor Location and Spacing for the 7250X Series

Installation of PVDF Probe

CAUTION

NOTE: The surface of the isolating material (PVDF) exceeds the limit of 4cm² as specified in EN60079-26, and the probability of electrostatic charging needs to be considered for use in category 1 (Zone 0).

Part of the equipment enclosure is constructed of non-metallic material; to prevent the risk of electrostatic sparking, the non-metallic enclosure material should be cleaned only with a damp cloth.

Specific Conditions of Use:

The equipment contains non-metallic enclosure parts, to prevent the risk of electrostatic sparking the non-metallic surface should only be cleaned with a damp cloth.

Installation

IMPORTANT

Be sure to read & understand all of the Instructions before beginning.

Unpacking

Carefully remove the contents of the shipping carton and check each item against the packing list before destroying any packing materials.

Storage

Level gauge probes should be stored in their original shipping containers until ready for installation. Damage that occurs in storage is not covered under manufacturer warranty.

Mounting Conditions

CAUTION

- When installing probes, do not bend rigid probes, permanent damage may result.
- Longer rigid probes need to be supported at both ends while handling.
- Probes are sealed at the factory and contain no user serviceable components.
- Do not attempt to open probe or weld the tube.
- Level gauge probes are designed for industrial applications, but should be mounted in a location as free as possible from vibration, corrosive atmospheres, or any possibility of mechanical damage.
- Place the level gauge in a reasonably accessible location, ambient temperature should be between -40°F and 158°F (-40°C to 70°C).
- Mount the Level gauge probe perpendicular with gravity.
- Float should have free movement along probe.
- Float retention clip should be in place at base of probe.

Mounting Considerations

Mounting considerations may vary (Flanges, Compression Fitting, etc.) depending on the application. For underground tanks, the probe is generally mounted in the riser, resting on the bottom of the tank. Spacers are used to hold the sensor in the center of the riser. While most underground tanks are horizontal and fairly standard in design, above ground tanks vary considerably. The requirements for mounting these probes are fairly simple. Since the probe requires a float to provide level position, there is a minimum size required for insertion of the float into the tank.

It is recommended that a minimum of a 2" NPT pipe opening be used.

Installation Note:

On probes with Connector Style V (Flexible Tube) installation into tank must occur within 12 months of shipment date. This will minimize any damage caused by storing the probe in a coiled position.

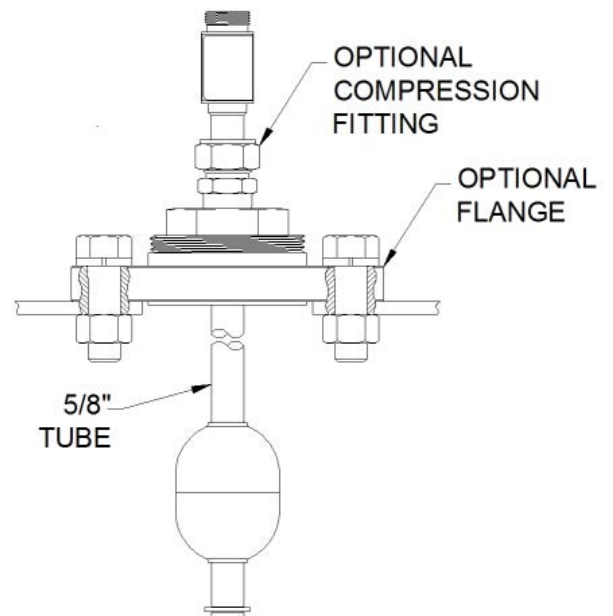
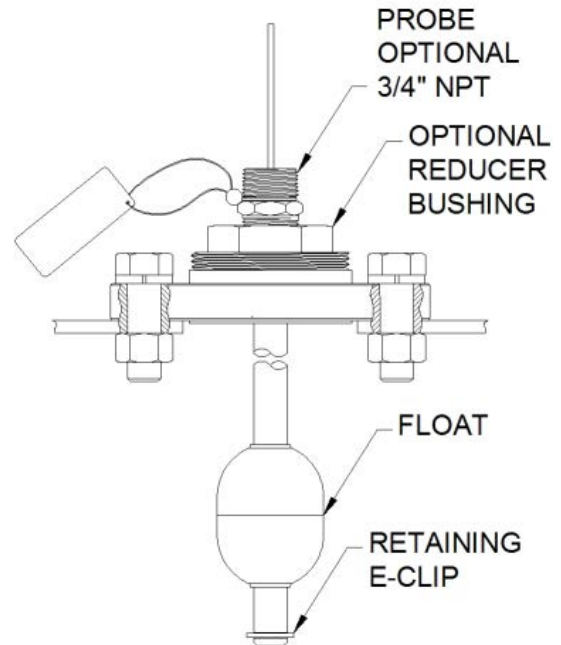

7250 Series Specifications

Specifications			
Indicated Level up to one product reading and one interface reading		Logic Levels	V_{OH} 2.7v (Leakage current is less than 1 μ A) V_{OL} 0.4v (5mA load) V_{IH} 2.1v V_{IL} 0.9v
316 Stainless Steel Resolution ¹ Repeatability Linearity Hysteresis	Lengths up to 288" 0.0001" Equal to Resolution +/- 0.01% ² +/- 0.002% ³		
PVDF (Rigid) Resolution ¹ Repeatability Linearity Hysteresis	Lengths up to 192" 0.0001" Equal to Resolution +/- 0.01% ² +/- 0.002% ³	Cable The cable will be a shielded 3 conductor 22AWG with a PVC jacket (Belden 6501FE or equivalent)	Red Power White Data Signal Black Common Drain Cable shield, Chassis ground on S.S. housing probes
PVDF (Flexible) Resolution ¹ Repeatability Linearity Hysteresis	Lengths from 193" up to 840" 0.0001" Equal to Resolution +/- 0.01% ⁴ +/- 0.002% ³		
Indicated Temperature up to 5 temperature sensors	Resolution Repeatability Accuracy 0°C to +100°C -40°C to -1°C & +101°C to +125°C	Data Update Time ¹ Position data Temperature data	0.100 seconds 0.800 seconds
Power Supply Voltage Current (@+5VDC)	+5 VDC, +/- 10 % typical (+3.7VDC Minimum) 10mA max. (8mA typical) plus 1.5mA max (1mA typical) per temperature sensor	Intrinsically Safe Entity Parameters	V_{max} 7.93 V I_{max} 280 mA P_i 1.0 W C_i 30.1 μ F L_i 0 μ H

Operating Temperature: -40°C to 70°C (Consult Factory for Higher Temperatures)



Specifications are subject to change without notice. Patented.

¹ protocol dependent

² or +/- 0.015", whichever is greater

³ or +/- 0.005", whichever is greater

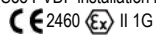
⁴ or +/- 0.039", whichever is greater

Hazardous Areas Approvals		Sanitary Approvals
FM -40° ≤ Tamb ≤ 70° C Class I, II, III, Div. 1 Groups C, D, E, F, G, T4 Class I, Div. 2 Groups A, B, C, D, T4 Class I, Zone 0, AEx/Ex ia IIB T4 Ga 	ATEX Ex ia IIB T4 Ga FM13ATEX0102X IECEx FMG 12.0008X Issued Date: 06/29/12 EN IEC 60079-0:2018 IEC 60079-11:2011 INMETRO DNV 14.0106X (See PVDF installation note) 	

7250 Series Part Numbering Sequence

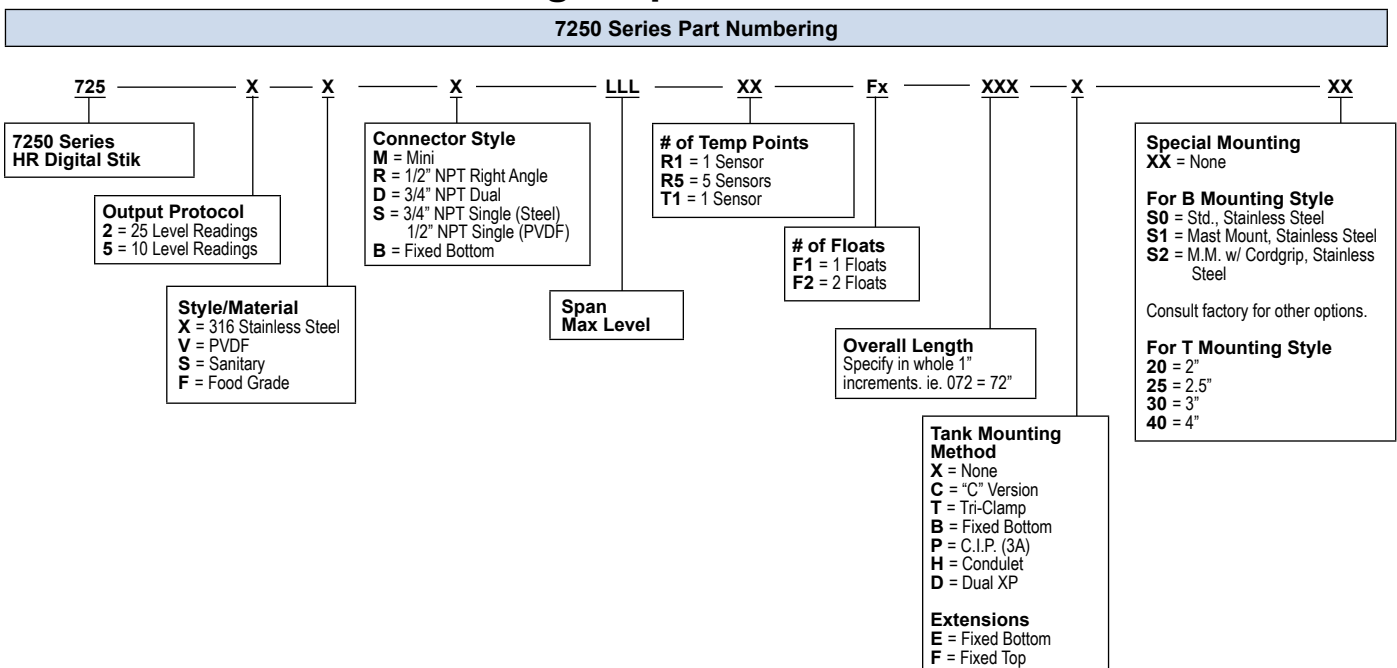

7250 Installation Drawing

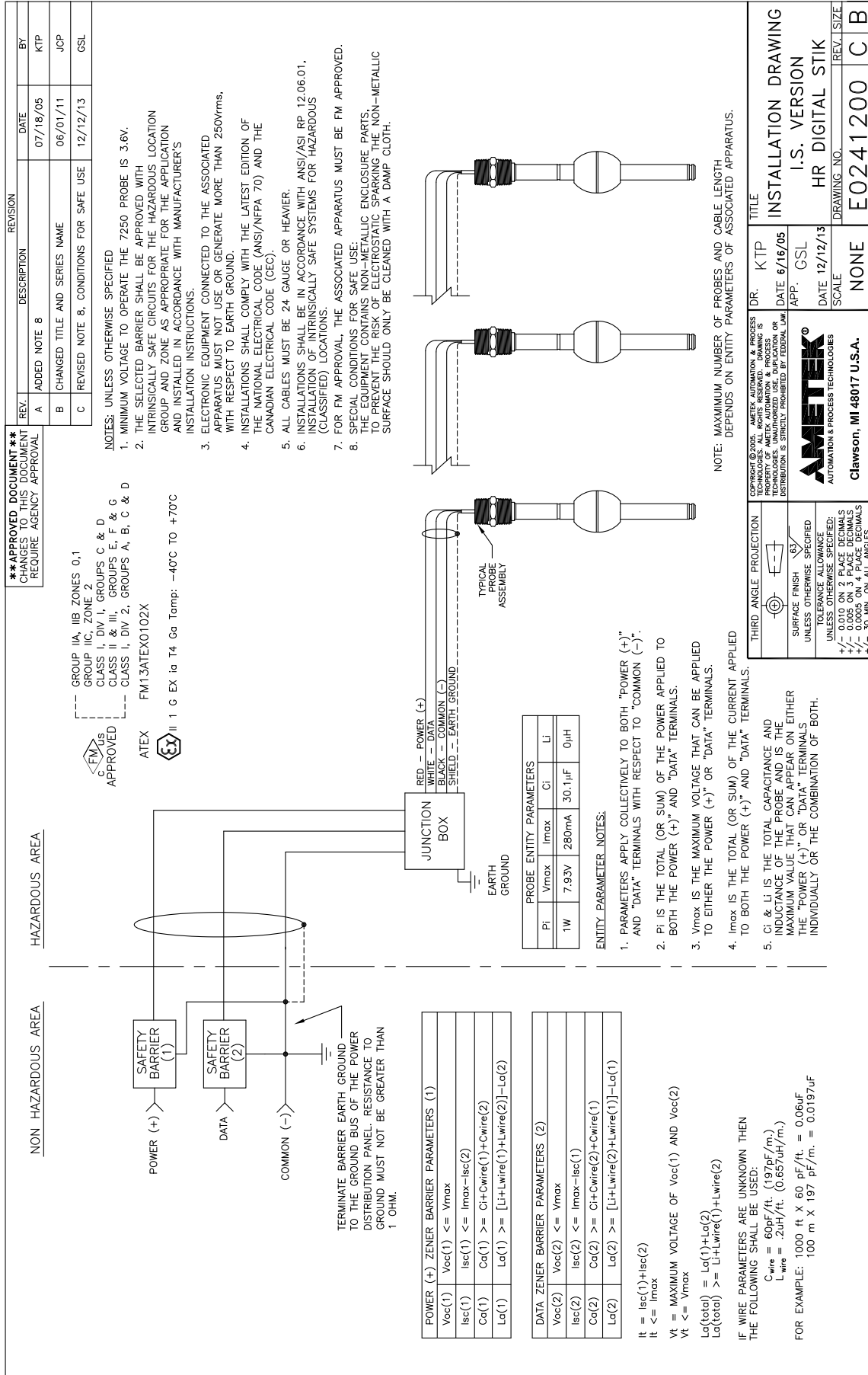

7250 Dimension Drawing

REVISION			
REV.	DESCRIPTION	DATE	BY
E	UPDATED CHARTS FOR V & VB PROBES	12/04/08	KTP
F	UPDATED CHARTS FOR LONG PROBES	1/16/09	KTP
G	UPDATED R1 & T1 OPTIONS FOR VB	11/5/09	MJD

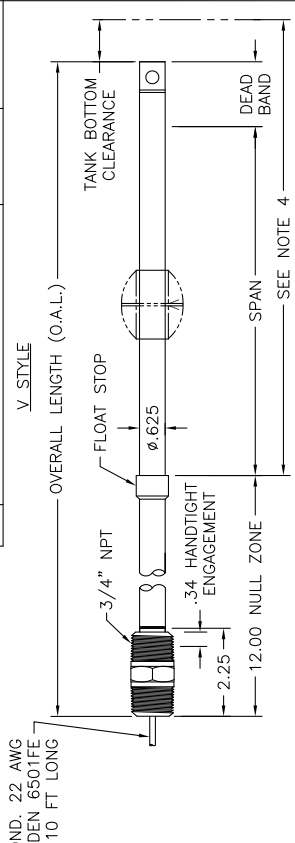

Ø A.L. (in)	DEAD BAND (in)	TANK BOTTOM CLEARANCE (in)
47-144	6.00	1.00
145-288	8.00	2.00
289-432	12.00	3.00
433-600	15.00	4.00
601-720	17.00	5.00
721-940	19.00	6.00

NOTE:
 FOR DUAL FLOAT PROBES WITH OVERALL LENGTH GREATER THAN 288", A FLOAT SPACER WILL BE REQUIRED BETWEEN TWO FLOATS.

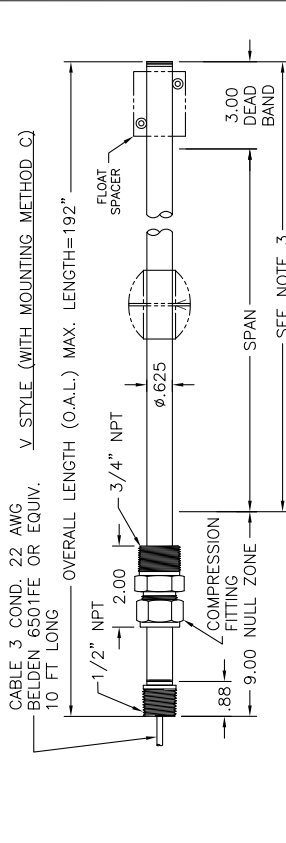

NOTE:
 1. OPERATING TEMPERATURE OF V-C STYLE PROBE IS 0-40°C (32-104°F)
 2. ALL DIMENSIONS ARE FOR REFERENCE ONLY.
 3. TEMPERATURE SENSORS ARE SPACED EQUALLY OVER RANGE SPECIFIED.
 4. TEMPERATURE SENSORS ARE SPACED EQUALLY OVER TEMPERATURE SPAN + DEAD BAND + TANK BOTTOM CLEARANCE

SHEET 1 OF 2

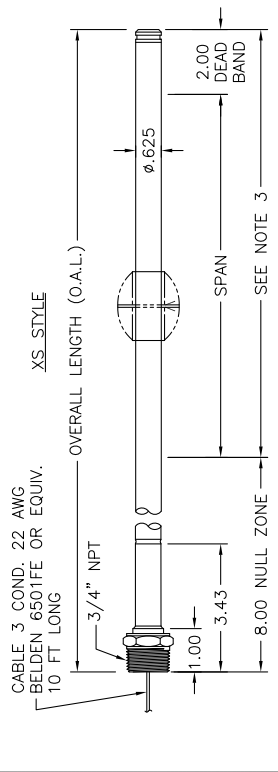
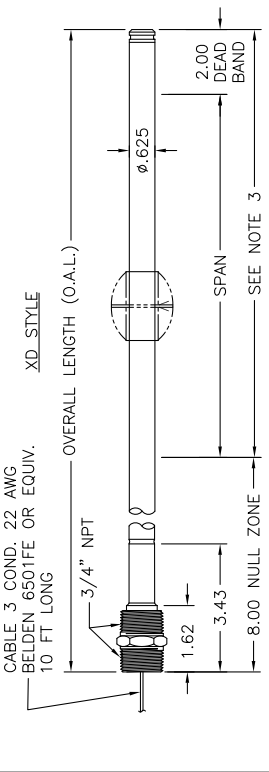
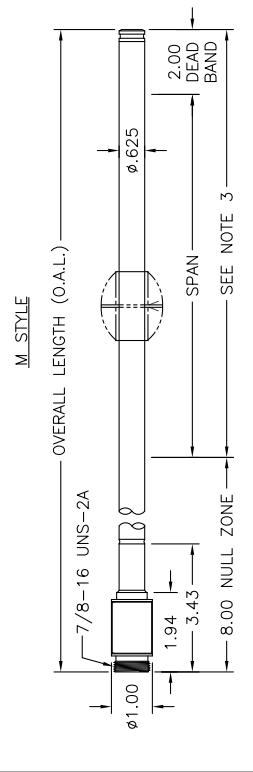
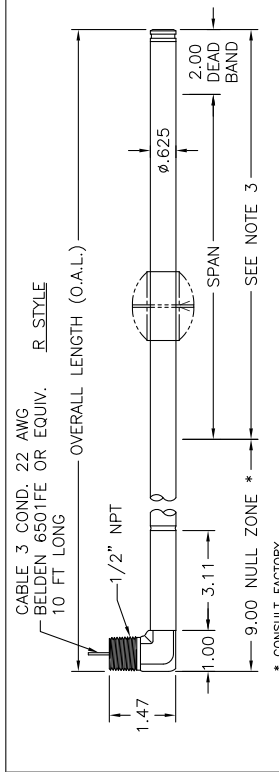

THIRD ANGLE PROJECTION	DR. K.P.	TITLE
SURFACE FINISH 63/	DATE 03/17/05	DIMENSION DRAWING
UNLESS OTHERWISE SPECIFIED	APP. B.D.B.	7250 SERIES HR
TOLERANCE ALLOWANCE	DATE 04/19/17	DIGITAL STIK (2 SHEETS)
UNLESS OTHERWISE SPECIFIED:	SCALE	DRAWING NO.
+/- 0.010 ON 2 PLACE DECIMALS	NONE	DO246600
+/- 0.0005 ON 4 PLACE DECIMALS		
+/- 30 MIN. ON ALL ANGLES		
		REV. SIZE
		G B

PROPERTY OF AMETEK AUTOMATION & PROCESS TECHNOLOGIES
 DISTRIBUTION IS STRICTLY PROHIBITED BY FEDERAL LAW

AMETEK®
 AUTOMATION & PROCESS TECHNOLOGIES
 Clawson, MI 48017 U.S.A.

7250 Dimension Drawing

REV.	DESCRIPTION	DATE	BY
E	UPDATED CHARTS FOR V & VB PROBES	12/04/08	KTP
F	UPDATED CHARTS FOR LONG PROBES	1/6/09	KTP
G	UPDATED R1 & T1 OPTIONS FOR VB	11/5/29	MJD

STANDARD PROBE LENGTHS:

PROBE TYPE	MAXIMUM O.A.L. (in)	MINIMUM O.A.L. (in)
M.S.D (RS)	288	53
M.S.D (R1)	288	34
M.S.D (T1)	288	20
R (RS)	288	53
R (R1)	288	35
R (T1)	288	21
V (RS)	840	65
V (R1&T1)	840	47
V-C (RS)	192	69
V-C (R1&T1)	192	25
VB (RS)	862	211

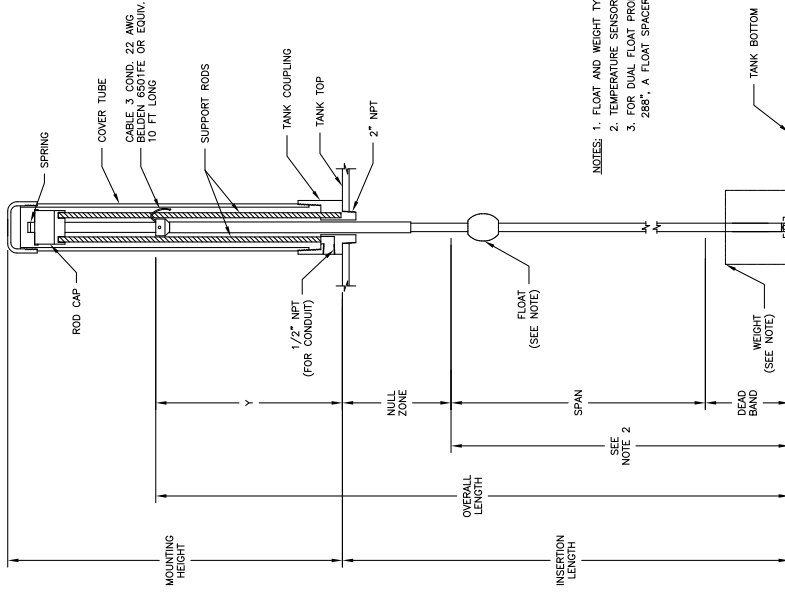

- NOTES: 1. FLOAT AND WEIGHT TYPE & GEOMETRY ARE DEPENDANT ON APPLICATION.
 2. TEMPERATURE SENSORS ARE SPACED OVER RANGE SPECIFIED.
 3. FOR DUAL FLOAT PROBES WITH OVERALL LENGTH GREATER THAN 288", A FLOAT SPACER WILL BE REQUIRED BETWEEN TWO FLOATS.

THERMOMETER SPACING

M.S.D.R.V.-C STYLE PROBE SINGLE THERMOMETER PROBES:

PROBE TYPE	OVERALL PROBE LENGTH	THERMISTOR SPACING @ 24°C
M.S.D&R (R1)	ALL STD. LENGTHS	18"
M.S.D&R (T1)	ALL STD. LENGTHS	4"
V (R1 & T1)	L ≤ 144"	27"
V	145" ≤ L ≤ 288"	30"
V (R1 & T1)	289" ≤ L ≤ 432"	35"
V (R1 & T1)	433" ≤ L ≤ 600"	39"
V	601" ≤ L ≤ 720"	42"
V (R1 & T1)	721" ≤ L ≤ 840"	45"
V-C	L ≤ 192"	5 1/2"
VB (R1 & T1)	211" ≤ L ≤ 862"	36"

M.S.D.R.V.-C STYLE MULTIPLE THERMOMETER PROBES:

PROBE TYPE	OVERALL PROBE LENGTH	THERMISTOR SPACING @ 24°C
M.S.D&R (RS)	ALL STD. LENGTHS	(TEMP. SPAN+2)/6
V-C	L ≤ 192"	(TEMP. SPAN+3)/6

V STYLE MULTIPLE THERMOMETER PROBES:

PROBE TYPE	OVERALL LENGTH (in)	FIRST THERMOMETER LOCATION FROM TANK BOTTOM @ 24°C	SECOND THERMOMETER LOCATION FROM TANK BOTTOM @ 24°C	SPACING BETWEEN THERMOMETERS
V (RS) **	65" ≤ L ≤ 144"	2*(TEMP. SPAN+7)/6	2*(TEMP. SPAN+7)/6	(TEMP. SPAN+7)/6
V (RS) **	145" ≤ L ≤ 215"	2*(TEMP. SPAN+10)/6	2*(TEMP. SPAN+10)/6	(TEMP. SPAN+10)/6
V (RS) **	216" ≤ L ≤ 288"	36"	36"	0.2 * (SPAN+10)
V (RS) **	289" ≤ L ≤ 432"	36"	36"	0.2 * (SPAN+15)
V (RS) **	433" ≤ L ≤ 600"	36"	36"	0.2 * (SPAN+19)
V (RS) **	601" ≤ L ≤ 720"	36"	36"	0.2 * (SPAN+22)
V (RS) **	721" ≤ L ≤ 840"	36"	36"	0.2 * (SPAN+25)

** TEMPERATURE SENSORS LOCATED WITH REFERENCE TO TANK BOTTOM.

V STYLE (WITH MOUNTING METHOD B)

OVERALL LENGTH = INSERTION LENGTH + Y

INSERTION LENGTH (in)	NULL ZONE @24°C (in)	DEAD BAND (in)	Y (in)	WEIGHT (SEE NOTE)	HEIGHT (in)	MOUNTING THERMOMETER LOCATION FROM TANK BOTTOM @ 24°C (in)	SECOND THERMOMETER LOCATION FROM TANK BOTTOM @ 24°C (in)	SPACING BETWEEN THERMOMETERS
192-288	211-307	10	3.65	19	35	0.2 * (SPAN+3.65)	0.2 * (SPAN+3.65)	0.2 * (SPAN+3.65)
289-432	311-464	12	6.25	22	35	0.2 * (SPAN+6.25)	0.2 * (SPAN+6.25)	0.2 * (SPAN+6.25)
433-600	453-622	15	6.50	22	35	0.2 * (SPAN+6.50)	0.2 * (SPAN+6.50)	0.2 * (SPAN+6.50)
601-720	623-742	16	7.00	22	37	0.2 * (SPAN+7.00)	0.2 * (SPAN+7.00)	0.2 * (SPAN+7.00)
721-840	743-882	21	7.00	22	37	0.2 * (SPAN+7.00)	0.2 * (SPAN+7.00)	0.2 * (SPAN+7.00)

** TEMPERATURE SENSORS LOCATED WITH REFERENCE TO TANK BOTTOM.

THIRD ANGLE PROJECTION

SURFACE FINISH: 63 UNLESS OTHERWISE SPECIFIED

TOLERANCE ALLOWANCE: UNLESS OTHERWISE SPECIFIED

+/- 0.010 ON 2 PLACE DECIMALS
 +/- 0.005 ON 3 PLACE DECIMALS
 +/- 0.0025 ON 4 PLACE DECIMALS
 +/- 30 MIN. ON ALL ANGLES

DR. K.P.
 DATE 03/17/05
 APP. B.D.B.
 DATE 04/19/17

TITLE: DIMENSION DRAWING 7250 SERIES HR DIGITAL STIK (2 SHEETS)

DRAWING NO. D0246600

REV. SIZE G B

AMETEK AUTOMATION & PROCESS TECHNOLOGIES
 Clawson, MI 48017 U.S.A.



Other Products



- GEMCO**
- LINEAR DISPLACEMENT TRANSDUCERS
- PLC INTERFACE PRODUCTS
- ROTARY POSITION PRODUCTS
- PROGRAMMABLE LIMIT SWITCHES
- EXTREME DUTY CABLE REEL PRODUCTS
- ROTARY LIMIT SWITCHES
- RESOLVERS
- MILL DUTY ENCLOSURES
- ULTRA HIGH SPEED PLS
- SAFETY PRODUCTS

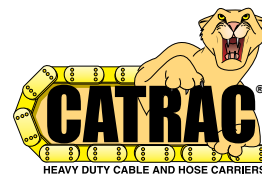

Copyright 2021
All Rights Reserved. Made in the USA.