

DREXELBROOK[®]

Model DDMC

Digital Meter / Controller



Description

The AMETEK Model DDMC Digital Meter/Controller powered by 85 to 265 VAC will display data from transmitters, transducers, scales, and other process instruments. It provides 24 volt excitation, alarm relays, and optional analog output for process control functions.

Features

- 0-20 mA, 4-20 mA, 0-5 V, 1-5 V, and ± 10 V Inputs
- NEMA 4X, IP65 Front
- Universal 85-265 VAC or 12/24 VDC Input Power
- Large Dual-Line 6-Digit Display, 0.60" & 0.46"
- Dual-Scale for Level Applications – Single Input
- Sunlight Readable Display Models
- Isolated 24 VDC @ 200 mA Transmitter Power Supply
- Math Functions for Flow & Round Horizontal Tanks
- Programmable Displays & Function Keys
- 32-Point, Square Root, or Exponential Linearization
- Multi-Pump Alternation Control
- 2 or 4 Relays + Isolated 4-20 mA Output Options
- External 4-Relay Expansion Module
- USB Serial Communication Options

Model DDMC

Specifications

Display

- Main display: 0.60" (15 mm) high, red LEDs
Second display: 0.46" (12 mm) high, red LEDs
6 digits each (-99999 to 999999), with lead zero blanking

Display Intensity

- Eight user selectable intensity levels

Display Update Rate

- 5/second (200 ms)

Overrange

- Display flashes 999999

Underrange

- Display flashes -99999

Programming Methods

- Four front panel buttons, digital inputs, PC and multi-point linearization utility, or cloning using Copy function.

Noise Filter

- Programmable from 2 to 199 (0 will disable filter)

Filter Bypass

- Programmable from 0.1 to 99.9% of calibrated span

Recalibration

- All ranges are calibrated at the factory. Recalibration is recommended at least every 12 months.

Max/Min Display

- Max/Min readings reached by the process are stored until reset by the user or until power to the meter is turned off.

Password

- Three programmable passwords restrict modification of programmed settings.
- Pass 1: Allows use of the F1–F3 function keys
Pass 2: Allows use of the F1–F3 function keys and changing the set/reset points
Pass 3: Restricts all programming and F1–F3 keys
- Note: Digital inputs are not password protected, except programming functions.

Non-Volatile Memory

- All programmed settings are stored in non-volatile memory for a minimum of ten years if power is lost.

Power Options

- 85-265 VAC 50/60 Hz, 90-265 VDC, 20 W max or jumper selectable 12/24 VDC \pm 10%, 15 W max

Fuse

- Required external fuse: UL Recognized, 5 A max, slow blow; up to 6 meters may share one 5 A fuse

Isolated Transmitter Power Supply

- Terminals P+ & P-: 24 VDC \pm 5% @ 200 mA max (standard), (12/24 VDC powered models rated @ 100 mA max).
5 or 10 VDC @ 50 mA max, selectable with internal jumper J4.

Normal Mode Rejection

- Greater than 60 dB at 50/60 Hz

Isolation

- 4kV input / output-to-power line 500 V input to-output or output-to-P+ supply

Overvoltage Category

- Installation Overvoltage Category II: Local level with smaller transient overvoltages than Installation Overvoltage Category III.

Environmental

- Operating temperature range: -40 to 65°C
Storage temperature range: -40 to 85°C
Relative humidity: 0 to 90% non-condensing

Connections

- Removable screw terminal blocks accept 12 to 22 AWG wire, RJ45 for external relays and serial communication adapters.

Enclosure

- 1/8 DIN, high impact plastic, UL 94V-0, color: black

Mounting

- 1/8 DIN panel cutout required:
3.622" x 1.772" (92 mm x 45 mm)
Two panel mounting bracket assemblies are provided.

Tightening Torque

- Screw terminal connectors: 5 lb-in (0.56 Nm)

Overall Dimensions

- 4.68" x 2.45" x 5.64" (119 mm x 62 mm x 143 mm) (W x H x D)

Weight

- 9.5 oz (269 g)

Warranty

- 2 years parts & labor

Model DDMC

Dimensions

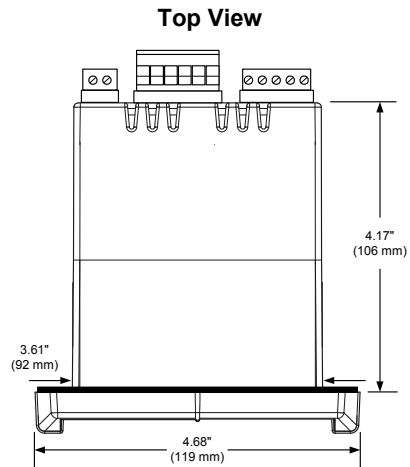
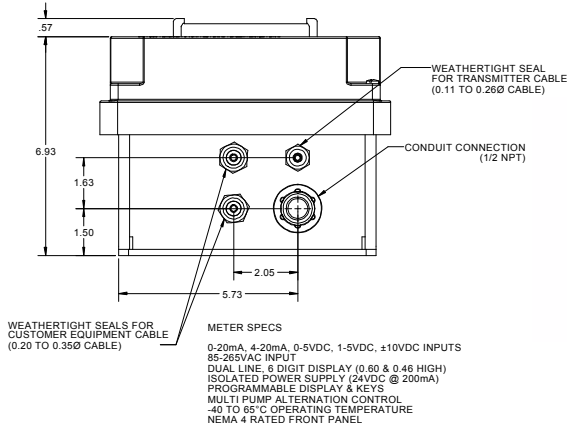
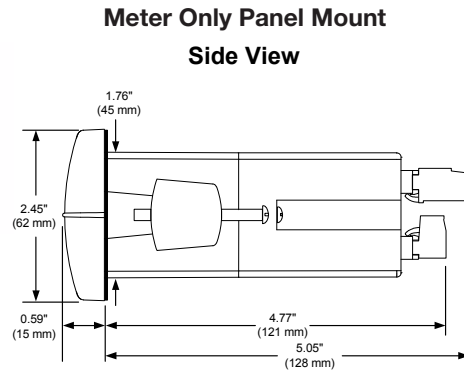
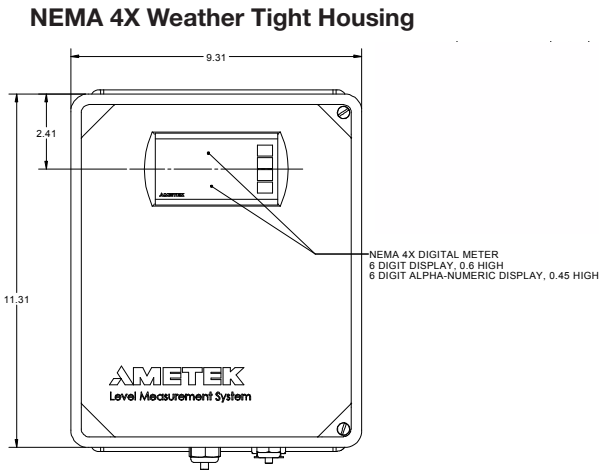

Model Numbering

- **DDMC Digital Meter / Controller**
- **DDMC** Digital Meter / Controller
- **Meter Output**
 - A** Two Relays
 - B** Two Relays, Analog Output 4-20mA
- **Housing**
 - 0** Panel-mount
 - 1** NEMA 4X Weather-tight Housing
- **DC Surge Protection**
 - 0** No DC surge protection
 - 1** Surge protection for signal line between meter and transmitter (LM912)
 - 2** Surge protection for signal line between meter and customer equipment (LM912)
 - 3** Surge protection for signal lines between meter & transmitter and meter and customer equipment (LM912 X 2)
- **AC Surge Protection**
 - 0** No AC surge protection
 - 1** 115 VAC surge protection for input line to the meter (LM918)
 - 2** 230 VAC surge protection for input line to the meter (LM919)

DDMC B 1 () ()

Model DDMC

Math Functions

Non-linear input signals (i.e. weirs & flumes, differential pressure, etc.) can be linearized with the DDMC's simple to use built-in math functions, such as: square-root extractor, exponential linearizer, horizontal round tank linearizer, or the DDMC's powerful general purpose 32-point linearizer.

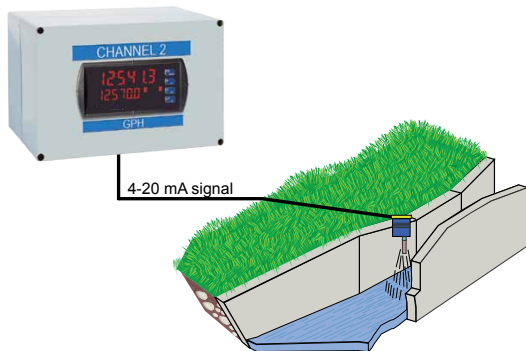

Weir Flow Calculated Using Exponential Math Function

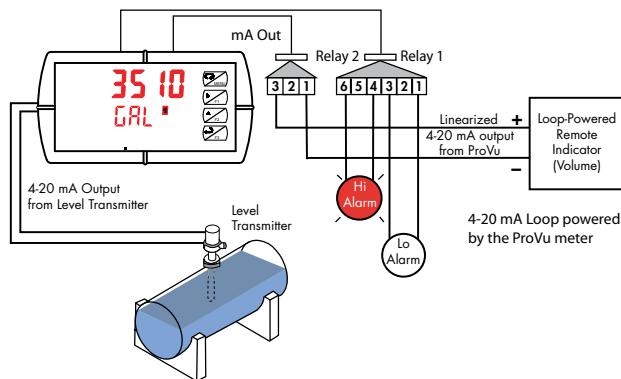

Round Horizontal Tank Math Function

Meter Copy

The Copy function is used to copy (or clone) all the settings from one meter to other meters requiring exactly the same setup and program-ming (i.e. type of input, scaling, decimal point, filter, bypass, etc.).



Relay Outputs

The DDMC has up to four 3 A Form C relays (SPDT) with multiple power loss fail-safe options. Relays can be configured for proper protective action upon input loop break. Relay ON and OFF delay times are user adjustable. Up to eight front panel indicators show alarm and/or relay state. All relays can be configured for 0-100% deadband.

Relay Operation/Configuration

There are powerful relay functions that can be configured in the DDMC meter, including:

- Automatic reset only (non-latching)
- Automatic + manual reset at any time (non-latching)
- Latching (manual reset only)
- Latching with clear (manual reset only after alarm condition has cleared)
- Pump alternation control (automatic reset only)
- Sampling (activated for a user-specified time)
- User selectable fail-safe operation
- Relay action for loss (break) of 4-20 mA input signal
- Time delay (on and off), independent for each relay
- Manual control mode
- Interlock relay mode

Analog Output

The isolated analog retransmission signal can be configured to represent the process variable (PV), maximum (peak) value, minimum (valley) value, the value for any of the eight relay set points, or Modbus input. While the output is nominally 4-20 mA, the signal will accurately accommodate under- and over-ranges from 1 to 23 mA.

Manual Output Control

Take control of any output with this feature. All relays can be forced ON or OFF, and the 4-20 mA output signal can be set to any value within its range. When the relays and 4-20 mA output are controlled manually, an LED labeled "M" is turned on and the associated Alarm LEDs (1-8) flash every 10 seconds indicating that the meter is in manual control mode.

Model DDMC

Isolated Transmitter Power Supplies

A powerful 24 V @ 200 mA power supply is a standard feature on the DDMC meter. It can be configured for 5, 10, or 24 V (default) by means of a simple internal jumper (see manual). An additional power supply (24 V @ 40 mA) is standard with the 4-20 mA output option.

4-Relay Expansion Module

Relays: Four Form A (SPST) rated 3 A @ 30 VDC and 125/250 VAC resistive load; 1/14 HP (\approx 50 watts) @ 125/250 VAC for inductive loads.

Isolated 4-20 mA Transmitter Output

Output Source: Process variable (PV), max, min, set points 1-8, manual control setting, or Modbus input
Scaling Range: 1.000 to 23.000 mA for any display range

Calibration: Factory calibrated: 4.000 to 20.000 = 4-20 mA output

Analog Output Programming: 23.000 mA maximum for all parameters: Overrange, underrange, max, min, and break

Accuracy: $\pm 0.1\%$ of span ± 0.004 mA

Temperature Drift: $0.4 \mu\text{A}/^\circ\text{C}$ max from 0 to 65°C ambient, $0.8 \mu\text{A}/^\circ\text{C}$ max from -40 to 0°C ambient

Note: Analog output drift is separate from input drift.

Isolated Transmitter Power Supply: Terminals I+ & R: 24 VDC $\pm 5\%$ @ 40 mA maximum, may be used to power the 4-20 mA output or other devices.

External Loop Power Supply: 35 VDC maximum

Output Loop Resistance:

Power supply	Minimum	Maximum
24 VDC	10 Ω	700 Ω
35 VDC (external)	100 Ω	1200 Ω

Serial Communications

USB Serial Adaptor Kit - Allows for direct connection of a DDMC meter to the USB port of a PC

Process Input

Inputs: Field selectable: 0-20, 4-20 mA, ± 10 VDC (0-5, 1-5, 0-10 V), Modbus PV (Slave)

Accuracy: $\pm 0.03\%$ of calibrated span ± 1 count, square root & programmable exponent accuracy
range: 10-100% of calibrated span

Temperature Drift: 0.005% of calibrated span/ $^\circ\text{C}$ max from 0 to 65°C ambient, 0.01% of calibrated span/ $^\circ\text{C}$ max from -40 to 0°C ambient

Math Function: Linear, square root, programmable exponent, or round horizontal tank volume calculation.

Multi-Point Linearization: 2 to 32 points for PV or PV1. 2 to 8 points for PV2 (Dual-Scale Level feature)

Programmable Exponent: 1.0001 to 2.9999

Low-Flow Cutoff: 0-999999 (0 disables cutoff function)

Decimal Point: Up to five decimal places or none: d.ddddd, dd.dddd, ddd.ddd, dddd.dd, dddd.d, or dddddd.

Calibration Range: 4-20 mA: minimum span input 1 & input 2: 0.15 mA. ± 10 V: minimum span input 1 & 2: 0.10 V. An Error message will appear if input 1 and input 2 signals are too close together.

Input Impedance: Voltage ranges: greater than 1 M Ω . Current ranges: 50 - 100 Ω (depending on resettable fuse impedance).

Input Overload: Current input protected by resettable fuse, 30 VDC max. Fuse resets automatically after fault is removed.

Model DDMC

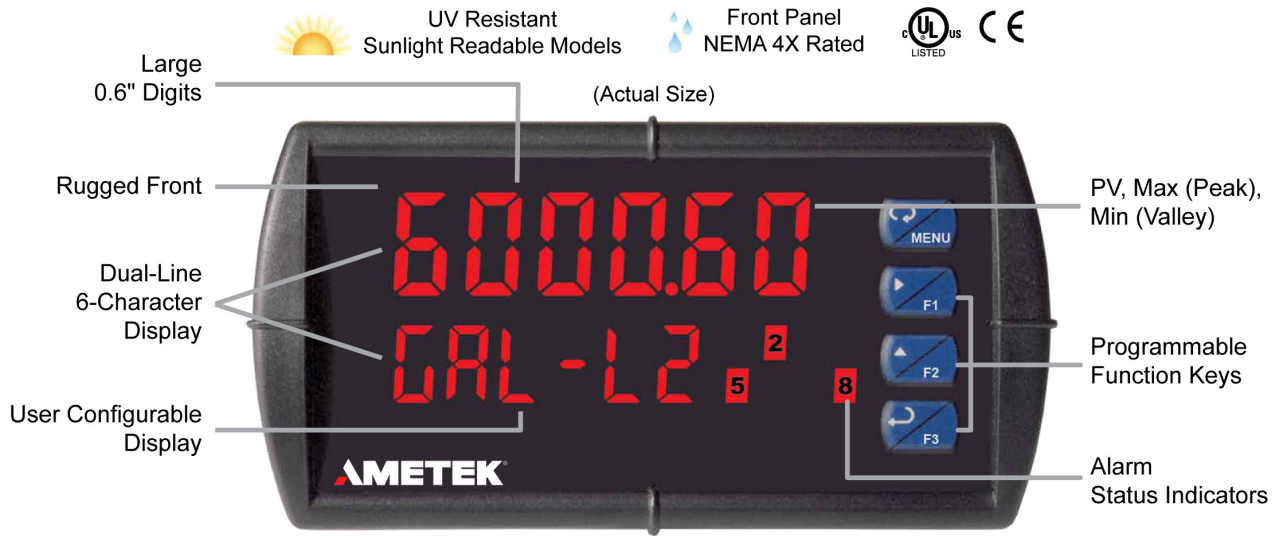

Feature Rich and Flexible

The DDMC® meter boasts specifications and functionality that clearly make it one of the most advanced process meters available. Its dual-line 6-digit display (999,999), advanced math functions, function keys, Modbus RTU serial communications, and optional expansion modules are only a few of the features found on the DDMC PD6000.

Front Panel Display

Precise, Accurate, and More Informative
DDMC large 0.6" upper display provides a highly accurate and precise 6-digit view of the process measurement. Its 24-bit A/D is accurate to $\pm 0.03\%$ of calibrated span ± 1 count.



Configurable

The upper display can be programmed to indicate PV, maximum (peak), minimum (valley), alternating maximum/minimum, one of eight alarm set points, or Modbus input. The lower display can also be configured to display engineering units, set points, user defined legends, or simply turned off.

Function Keys

There are three function keys available to the user. These keys can be programmed to trigger certain events (i.e. acknowledge alarms, reset max and/or min, disable/enable output relays, or hold current relay states), provide direct menu access points, and more.



Rugged

A unique front panel design makes the DDMC nearly impenetrable in typical applications. Here, the DDMC easily survives a direct hit on the display from a heavy 2" solid stainless steel ball dropped from eight feet.

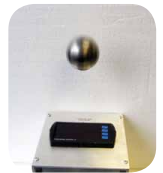

Easy to Use

The user friendly dual-line display makes the DDMC easy to set up & program. No jumpers to set for input selection. All setup & programming are done via the front panel. Three levels of password protection help maintain the reliability of the programming.



Model DDMC

Field Expansion modules

Add functionality to the DDMC in the field with easy-to-install external expansion modules. The menu items for these modules do not appear until the module is connected, simplifying the basic menu.

Relay Expansion Module

An external module containing four 3 A Form A (SPST) relays can be added to the DDMC at anytime. Removable screw terminal blocks accept 12 to 22 AWG wire.

Communication Module

Serial communications on the DDMC can be added anytime with external USB communication adapter Kit.

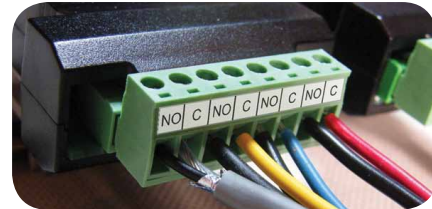

Multi-Pump Alternation

Up to 8 pumps can be alternated/sequenced.

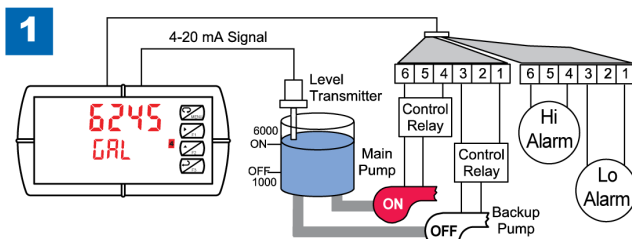

Relay #4 turns the main pump on at 6000 gallons and turns it off at 1000 gallons.

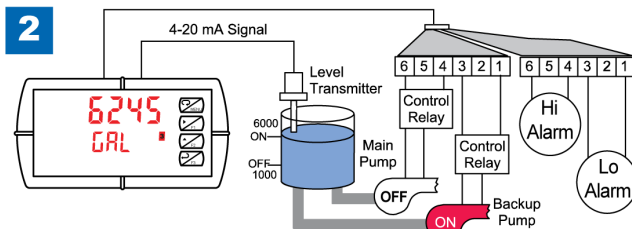

With the Pump Alternation feature activated, the next time the level reaches 6000 gallons, relay #3 transfers and starts the backup pump.

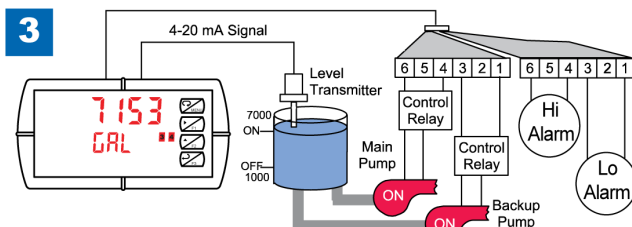

If the backup pump is not able to keep up, and the level reaches 7000 gallons, relay #4 transfers and starts the main pump as well.

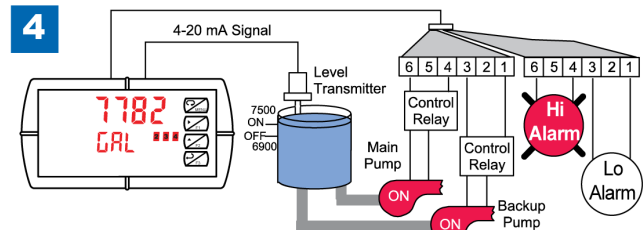

Relay #2 trips the High Level Alarm at 7500 gallons and resets at 6900 gallons.

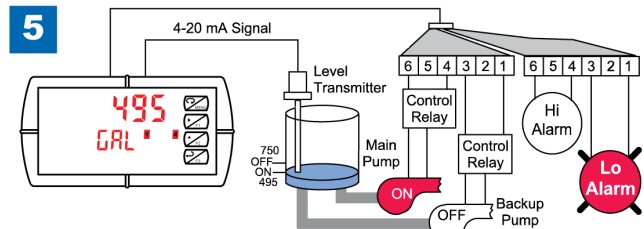

Relay #1 trips the Low Level Alarm at 495 gallons and resets at 750 gallons.

Model DDMC

Connections

- Form C (SPDT) relays
- Two isolated supplies available even on 12/24 VDC input power models
- Removable terminal blocks
- 2 or 4 relays + isolated 4-20 mA output option

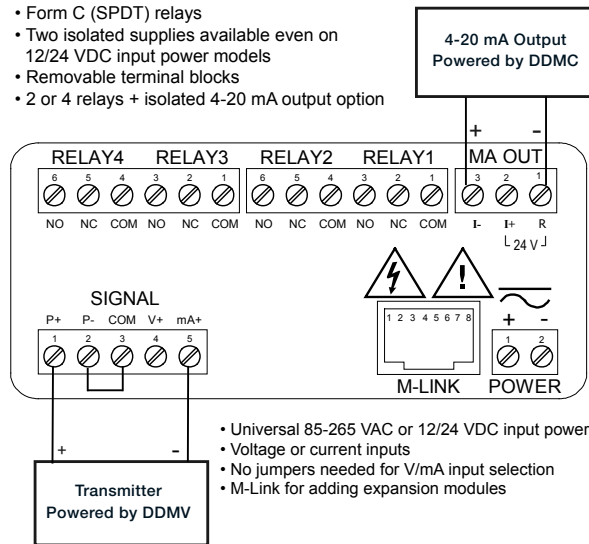

- Universal 85-265 VAC or 12/24 VDC input power
- Voltage or current inputs
- No jumpers needed for V/mA input selection
- M-Link for adding expansion modules

Relays

Rating: 2 or 4 SPDT (Form C) internal and/or 4 SPST (Form A) external; rated 3 A @ 30 VDC and 125/250 VAC resistive load; 1/14 HP (\approx 50 watts) @ 125/250 VAC for inductive loads such as contactors, solenoids, etc.

Noise Suppression: Noise suppression is recommended for each relay contact switching inductive loads.

Deadband: 0-100% of span, user programmable

High or Low Alarm: User may program any alarm for high or low trip point. Unused alarm LEDs and relays may be disabled (turned off).

Relay Operation: automatic (non-latching), latching (requires manual acknowledge), sampling (based on time), pump alternation control (2 to 8 relays), Off (disable unused relays and enable interlock feature, manual on/off control mode).

Relay Reset: User selectable via front panel buttons or digital inputs.

- Automatic reset only (non-latching), when input passes the reset point.
- Automatic + manual reset at any time (non-latching).
- Manual reset only, at any time (latching).
- Manual reset only after alarm condition has cleared (latching).

Note: Front panel button or digital input may be assigned to acknowledge relays programmed for manual reset.

Time Delay: 0 to 999.9 seconds, on & off relay time delays.

Programmable and independent for each relay.

Fail-Safe Operation: Programmable and independent for each relay.

Note: Relay coil is energized in non-alarm condition. In case of power failure, relay will go to alarm state. **Auto Initialization:** When power is applied to the meter, relays will reflect the state of the input to the meter.

Outputs

Relay Outputs

The PROVU has up to four 3 A Form C relays (SPDT) with multiple power loss fail-safe options. Relays can be configured for proper protective action upon input loop break. Relay ON and OFF delay times are user adjustable. Up to eight front panel indicators show alarm and/or relay state. All relays can be configured for 0-100% deadband.

Relay Operation/Configuration

There are powerful relay functions that can be configured in the DDMC meter, including:

- Automatic reset only (non-latching)
- Automatic + manual reset at any time (non-latching)
- Latching (manual reset only)
- Latching with clear (manual reset only after alarm condition has cleared)
- Pump alternation control (automatic reset only)
- Sampling (activated for a user-specified time)
- User selectable fail-safe operation
- Relay action for loss (break) of 4-20 mA input signal
- Time delay (on and off), independent for each relay
- Manual control mode
- Interlock relay mode

Analog Output

The isolated analog retransmission signal can be configured to represent the process variable (PV), maximum (peak) value, minimum (valley) value, the value for any of the eight relay set points, or Modbus input. While the output is nominally 4-20 mA, the signal will accurately accommodate under- and over-ranges from 1 to 23 mA.

Manual Output Control

Take control of any output with this feature. All relays can be forced ON or OFF, and the 4-20 mA output signal can be set to any value within its range. When the relays and 4-20 mA output are controlled manually, an LED labeled "M" is turned on and the associated Alarm LEDs (1-8) flash every 10 seconds indicating that the meter is in manual control mode.

Isolated Transmitter Power Supplies

A powerful 24 V @ 200 mA power supply is a standard feature on the PROVU meter. It can be configured for 5, 10, or 24 V (default) by means of a simple internal jumper (see manual). An additional power supply (24 V @ 40 mA) is standard with the 4-20 mA output option.