



1530 Side Mounted Pneumatic Level Switch

General Instructions

The side mounted SOR® 1530 Pneumatic Level Switch provides a pneumatic output signal for either a high or low level condition.



The float moves a magnet into the field of a magnetically actuated pneumatic valve. The pneumatic valve is pilot operated. An amplifying relay provides quick response.

The unit may be mounted for either high or low liquid level alarm by rotating the switch body. Wrench flats provide ease of rotation.

High Level Pneumatic Output Signal (Direct Acting) Install with pneumatic connections on the **upper** side of the body when the unit is tightened into the vessel.

Rising liquid level raises the float upward causing the float stem magnet to repel the actuating lever magnet and seal the pilot nozzle. Resultant pilot pressure build-up triggers the amplifying relay to pass pneumatic signal through the output port.

Low Level Pneumatic Output Signal (Reverse Acting) Install with pneumatic connections on the **lower** side of the body when the unit is tightened into the vessel.

Falling liquid level lowers the float downward causing the float stem magnet to repel the actuating lever magnet and seal the pilot nozzle. Resultant pilot pressure build-up triggers the amplifying relay to pass pneumatic signal through the output port.

NOTE: If you suspect that a product is defective, contact the factory or the SOR Representative in your area for a return authorization number (RMA). This product should only be installed by trained and competent personnel.

*Design and specifications are subject to change without notice.
For latest revision, go to www.sorinc.com*

Before Installing the Level Switch

- 1 Inspect the unit for any shipment damage.
- 2 Check for mechanical clearance. The float must move freely throughout its stroke inside the vessel.
- 3 Use an acceptable thread compound to ensure a leak free fit and avoid thread galling when installing the unit into the vessel.
- 4 The unit may be mounted in any of the following installation arrangements:
 - 2" NPT full or half coupling
 - 3" NPT full coupling (Use in conjunction with 2 x 3" NPT bushing.)
 - Optional flanged mounting
 - Optional chamber mounting
- 5 Clean dry air or gas must be used as the supply media to avoid plugging critical internal restrictions and nozzles.

SUPPLY PRESSURE RANGE: 20 TO 60 PSIG

Installation

- 1 Connect the supply line to the 1/8" NPT connection stamped Supply. Do not use pipe compound on the first two threads on pneumatic fitting. The supply media must be filtered and oil free. Air is the usual media; however, any dry filtered gas can be used.
- 2 Connect the output port stamped Output to the unit to be controlled.

NOTE: If the controlled device has a volume of less than 15 cubic inches, the small volume may cause the output to fluctuate. The addition of output volume will stop this fluctuation.



VENTING CAUTION: Note the position of the vent connection on the body. It must be positioned on a horizontal axis either on the right or the left side of the body. This connection must not be plugged. It is used for either local atmospheric venting or remote venting through a suitable line run to the designated venting area. Supply or Output connections must not be connected to the Vent port.

Float Attachment

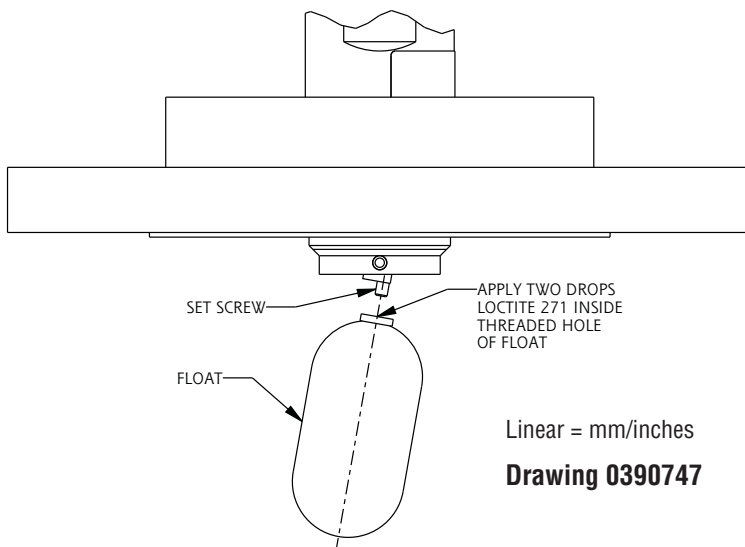

- 1 Place two drops of Loctite 271 inside the threaded hole of the float.
- 2 Thread the float onto the set screw and hand-tighten.

NOTE: Do not remove the set screw as it secures the pivot arm to the shaft.

Dimensions

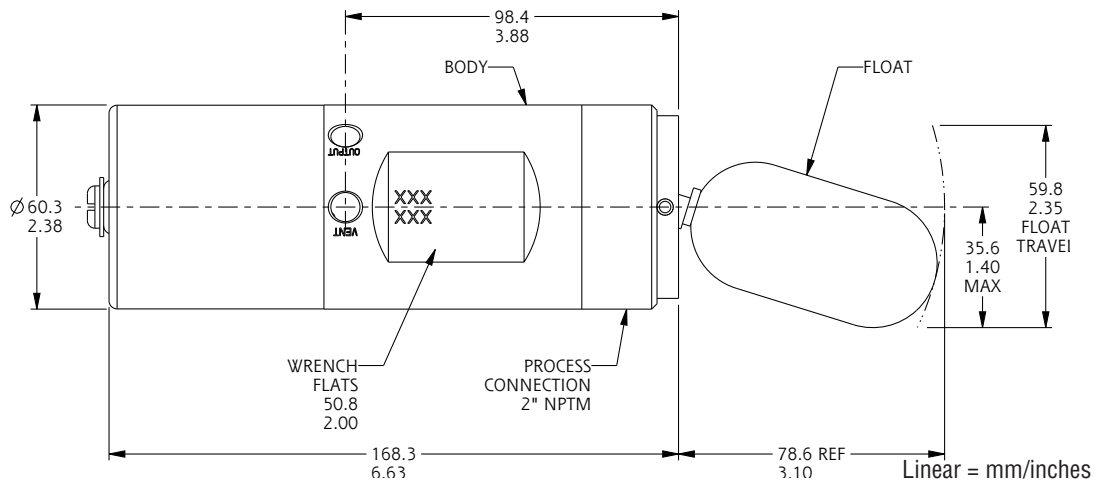

Drawing 0390026

1530 Operating Principle Schematic

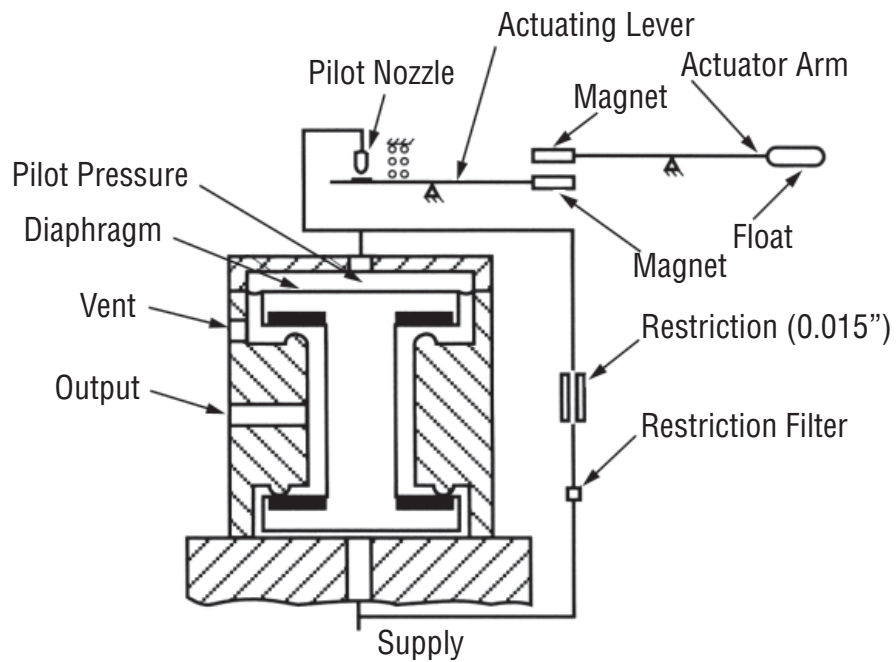

Troubleshooting

| Symptom | Probable Cause |
|---|---|
| Float in actuated position but no output signal. | <ul style="list-style-type: none"> a. Pilot nozzle-seat worn or damaged. (No seating of flapper.) Return to the factory or replace the switch. b. Actuating lever bound up or dirty. Clean or return to the factory. c. Damaged relay diaphragm. Replace the relay assembly. d. Relay orifice plugged. Clean. e. Insufficient supply pressure adjust to 20-60 psi. f. Output line clogged. Clean. |
| Float in de-actuated position but still receiving an output signal. | <ul style="list-style-type: none"> a. Pilot nozzle plugged. Clean the pilot nozzle. b. Actuating lever bound up or dirty. (Flapper remains seated.) Clean or return to factory. c. Vent screen clogged. Clean. |
| Control will not function when installed but operates when removed from vessel. | <ul style="list-style-type: none"> a. Inadequate float travel. Float travel restricted by the process connection. |
| Liquid in vessel at the actuation level but unit does not respond. | <ul style="list-style-type: none"> a. Leaky or collapsed float. Replace. b. Liquid specific gravity too low. c. Float stem bound up or dirty. Clean. d. Float travel is obstructed. Verify float can move freely and is not obstructed when installed. |
| Slow response. | <ul style="list-style-type: none"> a. Excessive volume in the output leg. b. Leaky output line. |
| Fluttering output. | <ul style="list-style-type: none"> a. Inadequate volume in the output leg. |

Replacement Parts

| Part Number | Description |
|-------------|-------------------------------------|
| 3130-052 | 316SS Float & Actuator Arm Assembly |
| 3130-114 | Pneumatic Relay Assembly |



sorinc.com

14685 West 105th Street, Lenexa, KS 66215 ■ 913-888-2630 ■ 800-676-6794 USA ■ Fax 913-888-0767