



Ultrasonic Two-Wire Point Level Control with Tip-Type Sensor

General Instructions

The Ultrasonic Point Level Control produces an 8mA or 16mA current to indicate liquid presence/absence within a sensor cavity. Two piezoelectric crystals face each other across the sensor cavity. One crystal transmits an ultrasonic signal; the other crystal receives the signal.

When the sensor cavity is empty, the receiver detects a weak signal because air is a poor conductor of ultrasonic waves.

When process liquid fills the sensor cavity, the receiver detects a strong signal because liquids are good conductors of ultrasonic waves.

The wet probe switch inside the electronics housing switches between 8mA and 16mA output in the wet probe condition. Internal LEDs indicate the current output over the loop. A red LED indicates 16mA current output, and a yellow LED indicates 8mA current output.

An optional timer is available to delay the current change from 0 seconds to 10 minutes. The delay timer provides added process control, valuable for use in turbulent conditions.

NOTE: If you suspect that a product is defective, contact the factory or the SOR® Representative in your area for a return authorization number (RMA). This product should only be installed by trained and competent personnel.

Design and specifications are subject to change without notice.

*For latest revision, go to **sorinc.com***

Table of Contents

Installation	2
Remote Cable Connection	3
Electrical Connection	4
Calibration and Functional Test	6
Delay Timer operation (DT accessory)	6
Time Delay Switch Settings	7
Troubleshooting	8
Sensor Replacement	8
Circuit Board Replacement	9
Cable Shielding	9
Dimensions	10
Control Drawings	11-14

Installation

Ultrasonic Level Sensors can be mounted by inserting the sensor through a fitting in a vessel, or the sensor may be suspended over an open sump or basin.

Keep the sensor cavity out of the direct flow of liquid fill to prevent false readings. Install a baffle to divert liquid flow if necessary.

Avoid installation of sensor in turbulent areas such as pump discharge or suction. Air pockets may be present in these areas which may cause false indication.



DO NOT weld any part of this instrument.

Tank or Vessel

Make sure that the sensor can be fully inserted and tightened without interference from obstructions inside the tank or vessel. (See **A**). The sensor cavity must clear the inner wall by one inch/25.4 mm. (See **B**)

Apply suitable sealant to the process connection to prevent process leakage. (See **A**)
Use an open end wrench to tighten the sensor into the process connection.
Do not use the sensor base as a handle to tighten the process connection.

Horizontal Mounting

Horizontal mounting is recommended for use in highly viscous liquids, or liquids containing sludge and debris. When tightened securely, the sensor cavity must be perpendicular to the liquid surface for optimum drainage when process liquid level drops below the sensor cavity.

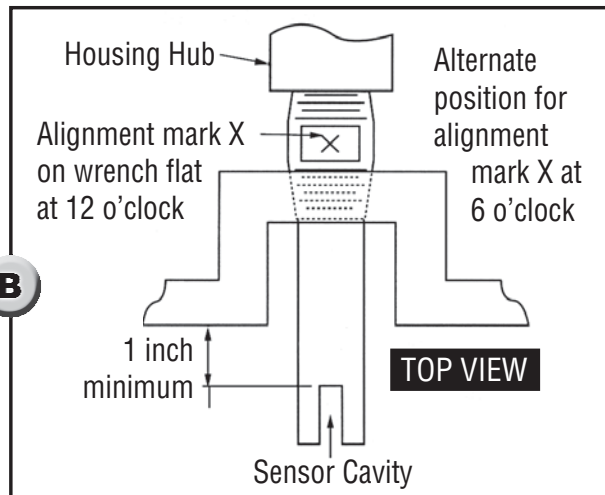
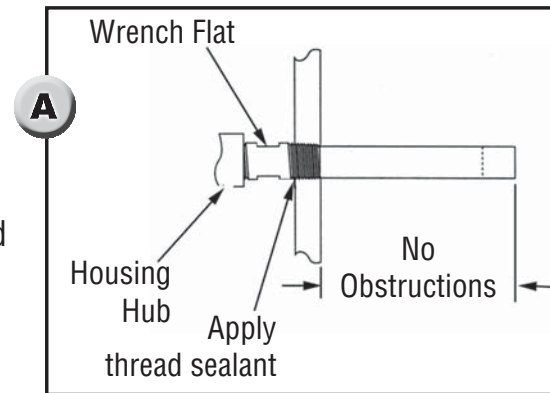

An alignment mark X stamped on a wrench flat (or on the dry face of a flange below the housing) shows sensor cavity orientation. (See **B**)

Optimum drainage occurs when the X mark is located at 6 or 12 o'clock. The sensor must project through a tank fitting so that the sensor cavity is at least 1" beyond the inner wall of the tank. (See **B**)

Open Sump or Basin

Do not suspend the unit by rigid conduit installed in the electrical hub. When installing the unit over an open sump or basin, use a suitable bracket to support the instrument.

NOTE: The instrument must be positioned so that overflow does not flood electrical housing. (See **C**)

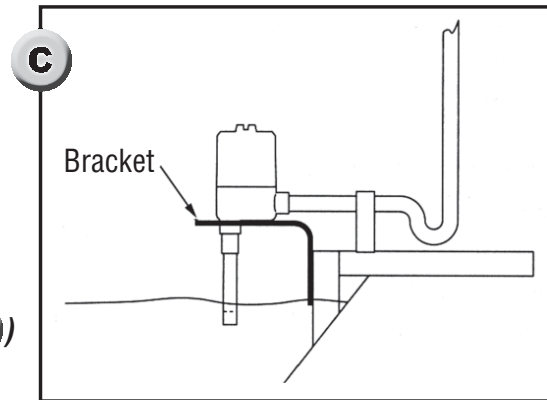

Remote Cable Connection

Conduit must be installed between the sensor base and the electronics housing to provide a raceway for sensor extension cables. (See **D**) The sensor base and the electronics housing are suitable for use in Class I Group C & D; Class II Groups E, F & G; Division 1 & 2 Hazardous Locations. All conduit and fittings used for the installation must equal or exceed this rating to maintain the explosion proof integrity of the assembly.

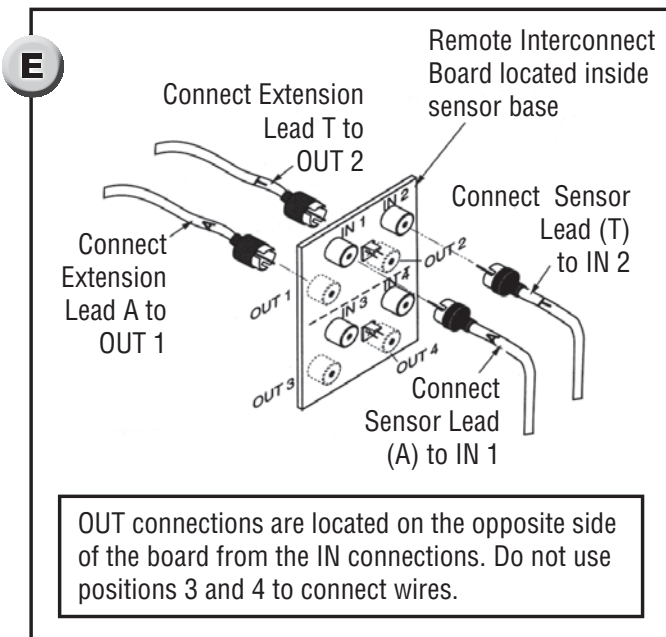
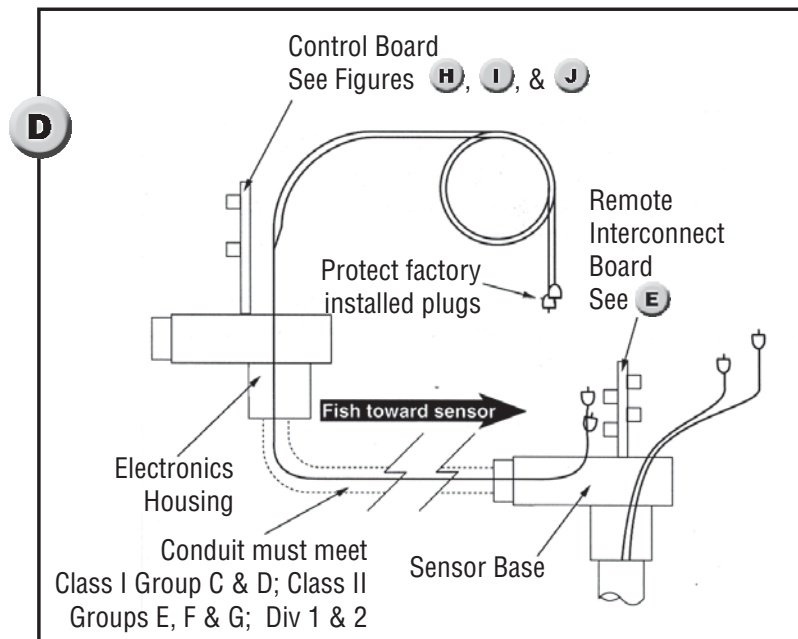

Fishing the sensor extension cables

Two sensor extension cables are supplied. Both ends of the cables are terminated and labeled at the factory. Use care to avoid damaging the factory installed coax connectors while fishing the sensor extension cables through the conduit. Pull cables from the electronics housing so that the free ends follow the fish through the conduit. (See **D**)

Electrical Connection

Ensure that wiring conforms to all applicable local and national electrical codes and install unit(s) according to relevant national and local safety codes.

Sensor Coax Connections Inside Sensor Base

Inside the sensor base, a remote interconnect board rests in a plastic holder. Slide the interconnect board up. Attach the sensor coax connectors to the interconnect board as follows:

- 1 Connect cable A to IN 1.
- 2 Connect cable T to IN 2.

Attach the extension cables to the interconnect board as follows:

- 3 Connect cable A to OUT 1.
- 4 Connect cable T to OUT 2. (See **E**)

Plug in Connections inside Electronics Housing Plug sensor extension cables onto the PC board as follows:

- 5 Connect cable A to J1.
- 6 Connect cable T to J2. (See **H** to locate J1 and J2.)

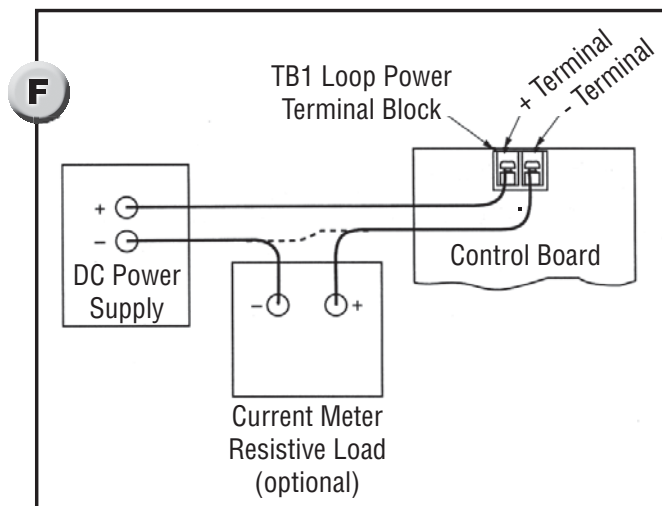

Units in Hazardous Locations — Prior to calibration, make sure that the work area is declassified before removing the explosion proof cover to calibrate the unit. Failure to do so could result in severe personal injury or substantial property damage.



Electrical power must be disconnected from explosion proof models before the cover is removed. Failure to do so could result in severe personal injury or substantial property damage.

Ensure that wiring conforms to all applicable local and national electrical codes and install unit(s) according to relevant national and local safety codes.

- ❶ Make sure the power source is turned off.
- ❷ Remove the housing cover.
- ❸ Pull power and signal wires through the conduit connection and into the control housing.
- ❹ Locate TB1 on the control board. (See **F**) Terminals are labeled “+” and “-”. Connect power leads to the proper terminals.
- ❺ Do not exceed the maximum loop resistance for the circuit. (See **G**)

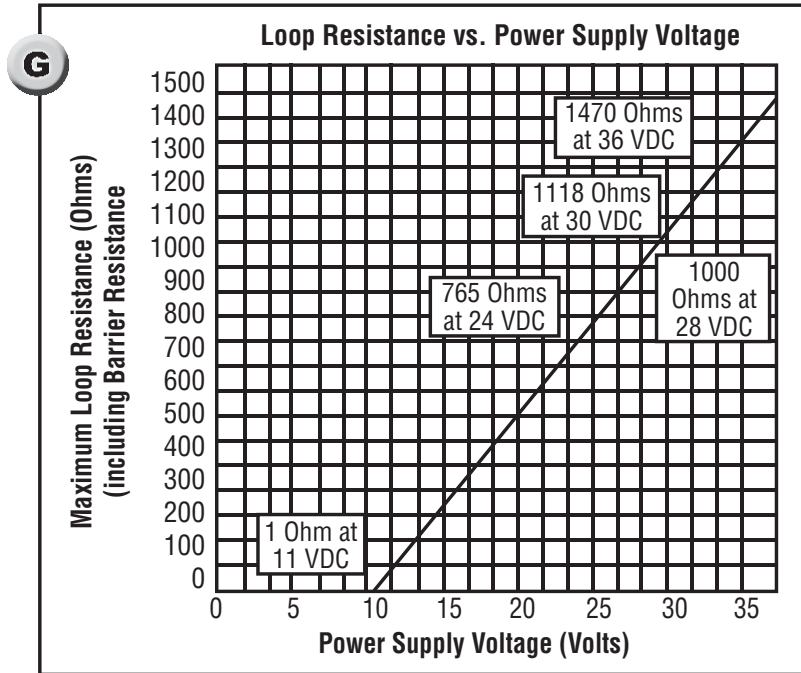

Calibration and Functional Test



Units in Hazardous Locations — Prior to calibration, make sure that the work area is declassified before removing the explosion proof cover to calibrate the unit. Failure to do so could result in severe personal injury or substantial property damage.

No calibration is needed. Units are calibrated at the factory. No user adjustments are required.

Functional test may be done with or without a current meter. See **F** for wiring configuration. See Figure 8 for component location.

- 1 Connect power to the circuit board as shown in **F**.
- 2 With a dry sensor, move the Wet Probe Switch (see **H**) to 8mA position. The red LED will light. The current meter will read 16mA (± 1 mA).
- 3 Apply process liquid to the sensor. The red LED will turn off, and the yellow LED will light. The current meter will read 8mA (± 1 mA).
- 4 With liquid still applied to the sensor, move the Wet Probe Switch to the 16mA position. The yellow LED will turn off, and the red LED will light. The current meter will read 16mA (± 1 mA).
- 5 Remove the liquid from the sensor. The red LED will turn off, and the yellow LED will light. The current meter will read 8mA (± 1 mA).

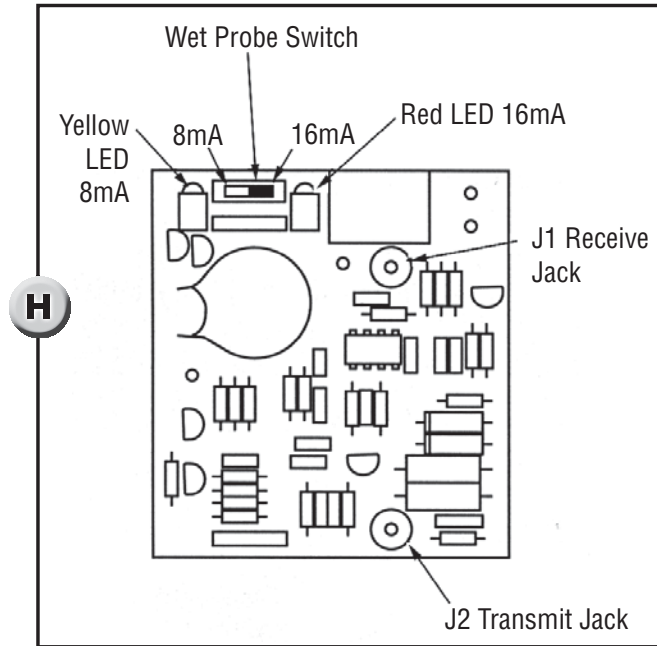

Delay Timer Operation (DT accessory)

Current Output Chart				
Yellow LED (Dry)	Red LED (Wet)	Current Meter (+ 1mA)	Sensor Status	Wet Probe Switch Position
○	●	8mA	Wet	8mA
●	○	16mA	Dry	8mA
●	●	16mA	Wet	16mA
○	○	8mA	Dry	16mA

The delay timer is present in units which contain a DT near the end of the model number. Time delays are available as shown in the Time Delay Switch Settings chart below. Two sets of switches located inside the electronics housing control the delay timer. (See **I**)

On Delay = sensor dry → sensor wet
 Off Delay = sensor wet → sensor dry

- 1** Remove the housing cover.
- 2** Locate off and on delay switches. (See **I**)
- 3** Set the on and off delay timers by moving the switches according to the chart below.

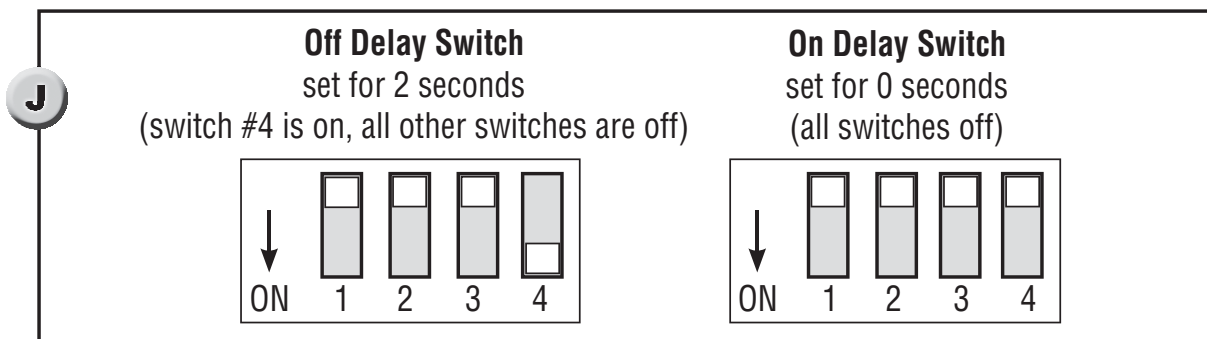
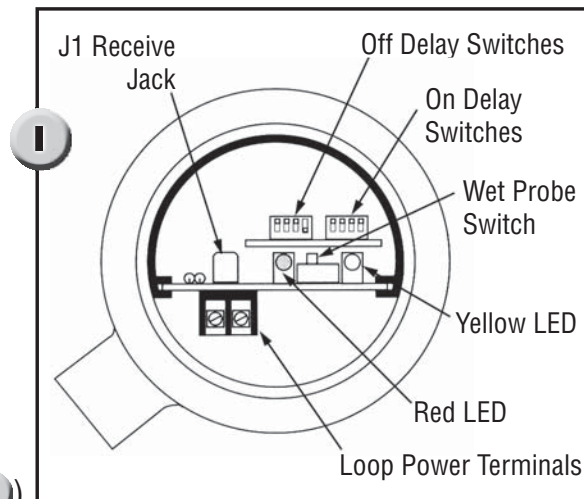

Time Delay Switch Settings				
Delay (seconds)	Position 1	Position 2	Position 3	Position 4
0	OFF	OFF	OFF	OFF
1	OFF	OFF	ON	ON
2	OFF	OFF	OFF	ON
5	OFF	OFF	ON	OFF
10	ON	ON	ON	ON
15	OFF	ON	OFF	OFF
20	ON	OFF	OFF	ON
30	ON	OFF	OFF	OFF
45	OFF	ON	OFF	ON
60	OFF	ON	ON	OFF
90	ON	ON	OFF	OFF
120	OFF	ON	ON	ON
180	ON	OFF	ON	OFF
240	ON	OFF	ON	ON
300	ON	ON	OFF	ON
600	ON	ON	ON	OFF

Troubleshooting		
Symptom/Problem	Possible Cause	Corrective Action
No current in the loop No LEDs lit	1. Power supply turned off. 2. Improperly wired terminal block TB1. 3. Broken power supply wire.	1. Check power supply source. 2. Check terminal block wiring per F . 3. Check loop wire integrity.
Current is greater than 20mA	1. Incorrectly wired circuit	1. Check current loop wiring per F .
Current is 8mA when 16mA is expected or current is 16mA when 8 mA is expected.	1. Wet probe switch is in the wrong position. 2. Time Delay has not timed out (units with DT accessory only).	1. Set wet probe switch to proper position. 2. Check time delay switches and wait for timeout or set new timeout or cycle power (turn off power then turn it back on.)

If corrective action is not effective, please consult the factory.

NOTE: Agency certified units, (FM, CSA, IEC) must be returned to SOR for repairs.

Sensor Replacement

- ❶ Disconnect power to the unit.
- ❷ Remove the housing cover.
- ❸ Slide out PC board to expose the sensor connections J1 and J2. (See **H**)
- ❹ Disconnect the sensor wires from J1 and J2.
- ❺ Unscrew the sensor from the housing.
- ❻ Apply thread sealant to the male threads of the new sensor.
- ❼ Thread the new sensor into the bottom of the housing.
- ❽ Connect one sensor wire into the J2 mini-phono jack on the circuit board.
- ❾ Connect the other sensor wire into the J1 miniphone jack on the circuit board.
- ❿ Slide the PC board into the grooves in the plastic ring inside the housing.
- ⓫ Reconnect power and replace the housing cover.

Replacement Sensors

See Form 973 Ultrasonic Catalog for replacement sensor model numbers.

Circuit Board Replacement

- 1 Disconnect power to the unit.
- 2 Remove the housing cover.
- 3 Slide out PC board.
- 4 Disconnect power wiring and sensor plugs J1 and J2. (See **H**) Remove the ground screw in the housing bottom.
- 5 Slide the ring terminal over the ground screw and replace it into the housing bottom.
- 6 Slide the new board into the control housing.
- 7 Connect the sensor plugs to the new board. One sensor wire plugs into J2. The other sensor wire plugs into J1.
- 8 Reconnect power and replace the housing cover.

Replacement Circuit Boards

Match the characters of your model number with those shown below to select the proper replacement board part number. Accessory designators are located at the end of the model number in no particular order.

Model Number	<u>Accessory Designator</u>	
	with DT	without DT
701 <input type="checkbox"/> 4-U-P9-C	38-123	38-125

Cable Shielding

In order to achieve the stated accuracy of ± 1 mA, a shielded cable, cable gland and shielded beads must be used. SOR recommends using a shielded cable made of PVC insulation around a tinned copper braid shield (Offlex CY cable or equivalent). Refer to illustrations below for installation of shield beads

Probe Wire Shield Bead

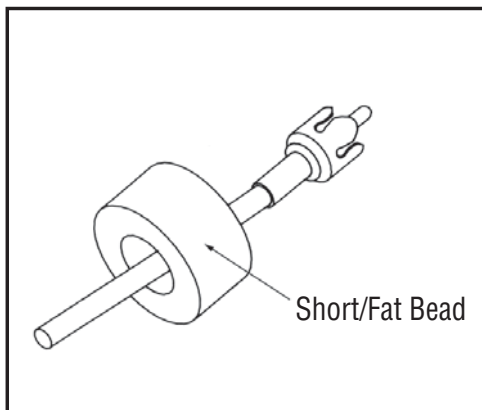

Power Wire Shield Bead

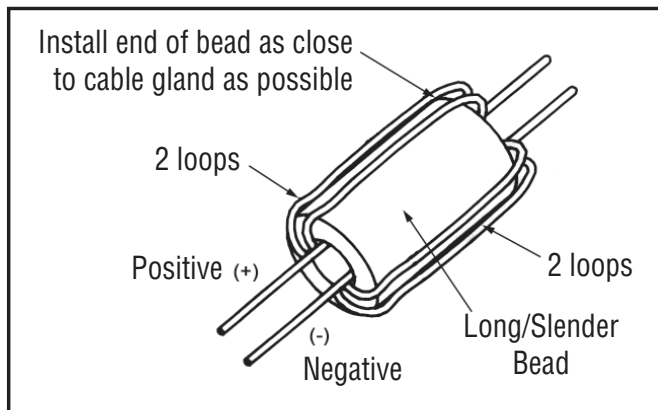

Dimensions

Remote Unit Electronics Housing

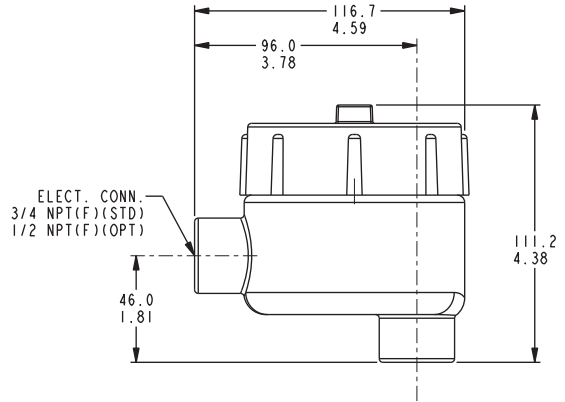
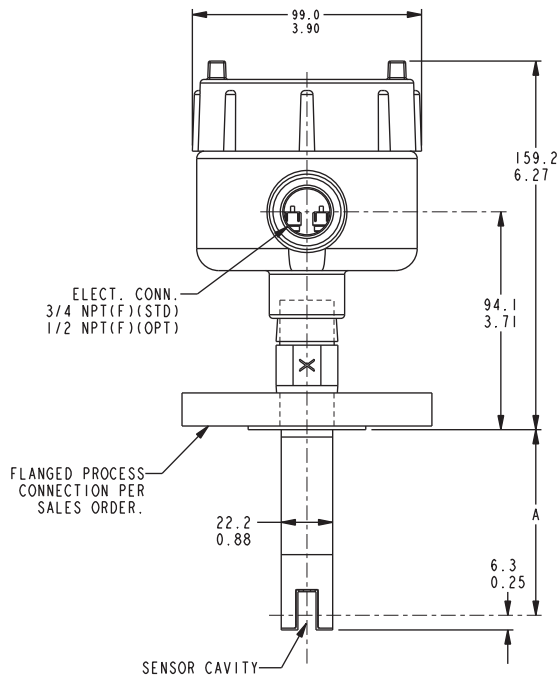

Linear = mm/inches

Drawing 0390529

*Dimensions are for reference only.
Contact the factory
for certified drawings
for a particular model number.*

Integral Unit or Remote Unit Sensor Housing

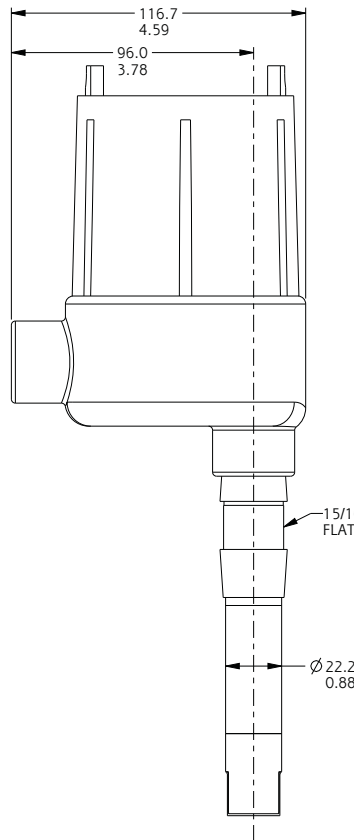
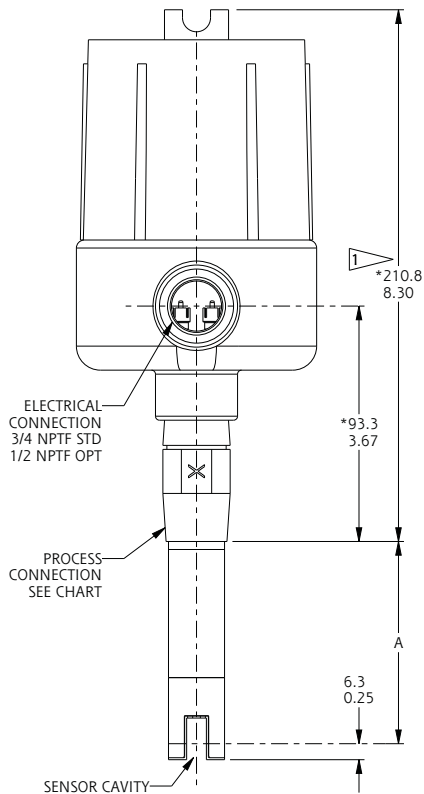

PROCESS CONN SIZE	* LENGTH
3/4 NPTM	SHOWN
1 NPTM	ADD 6.4 0.25
1-1/2 NPTM	ADD 7.1 0.28
2 NPTM	ADD 7.9 0.31
1 K1 HOUSING SHOWN ADD 50.8 2.00 FOR K2 HOUSING	
PROBE LENGTH A	

Linear = mm/inches

Drawing 0390415

Control Drawing

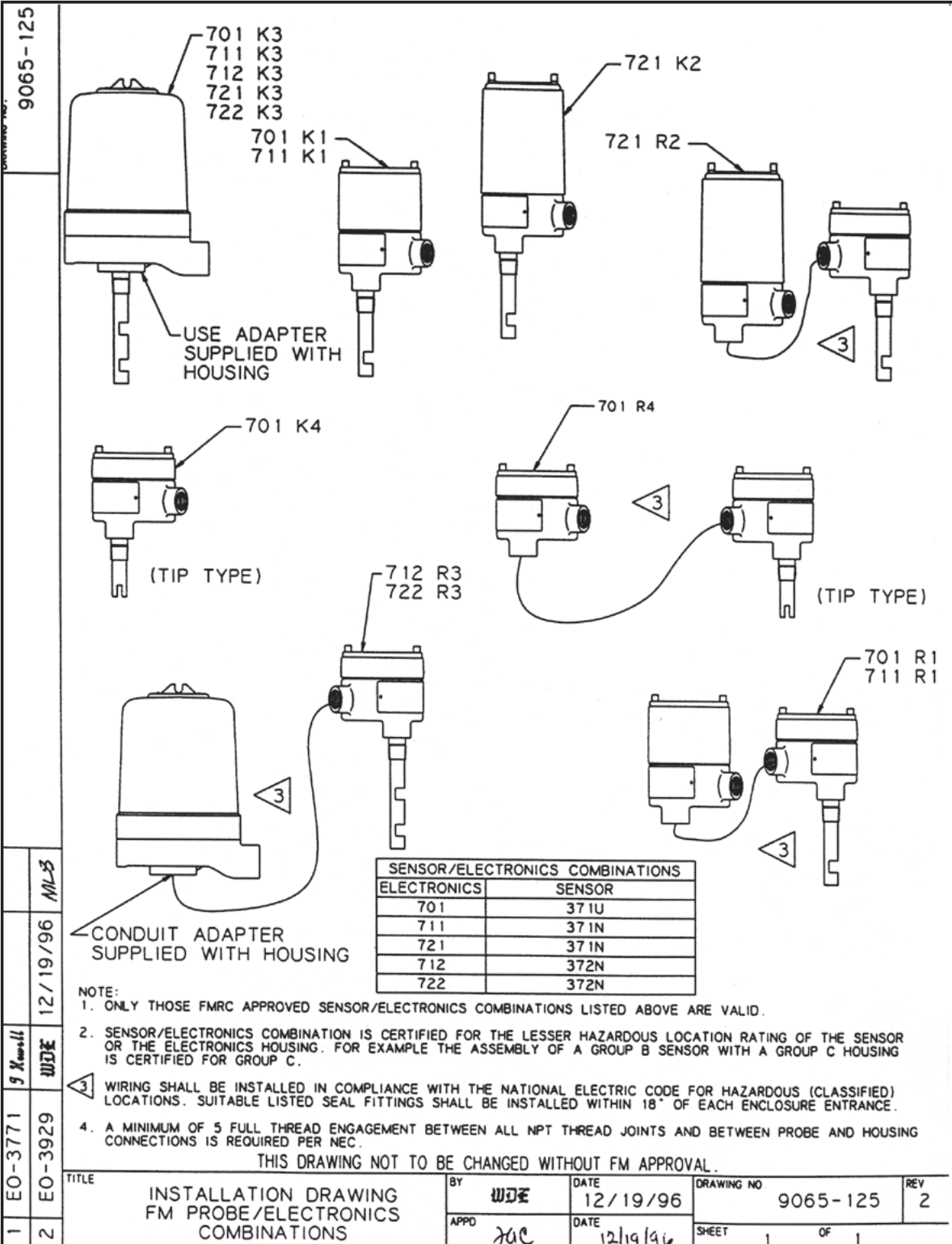

Control Drawing

14685 West 105th Street Lenexa, Kansas 66215 USA
Tel. 913-888-2630 Fax 913-888-0767

DRAWING NO. 9065-135

SERIES 700 TRANSMITTER FM APPROVED

INTRINSICALLY SAFE (ENTITY)

CLASS I, II, III, DIVISION 1, GROUP C, D, E, F, G
HAZARDOUS LOCATION
SERIES 7XXXX-X-P9-X-FI

NON-HAZARDOUS LOCATION
INTRINSIC SAFETY BARRIER

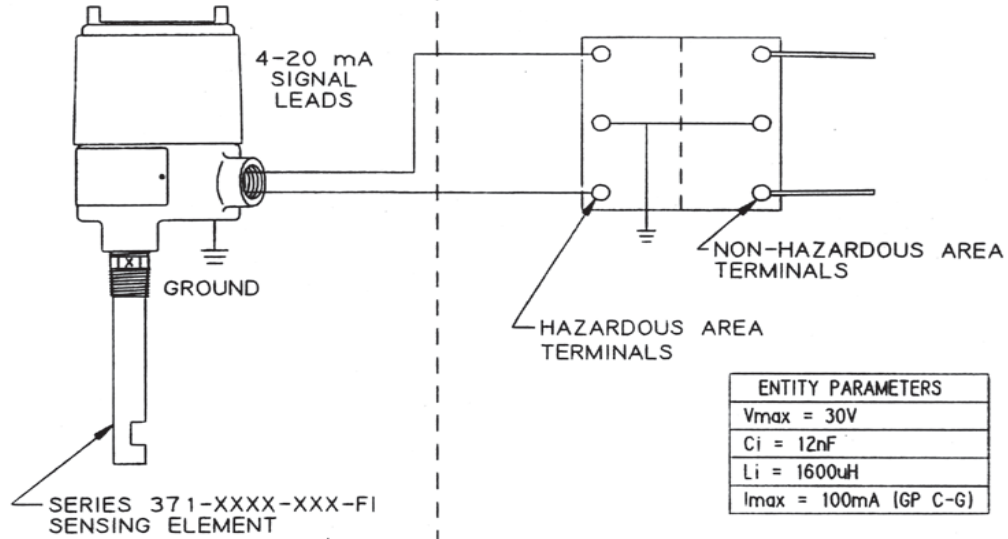

NOTES

1. FMRC ENTITY APPROVED BARRIER. USED IN AN APPROVED CONFIGURATION WHERE BARRIER V_{oc} OR V_t DOES NOT EXCEED TRANSMITTER V_{max} AND BARRIER I_{sc} OR IT DOES NOT EXCEED TRANSMITTER I_{max} . C_i OF TRANSMITTER PLUS CAPACITANCE OF INTERCONNECTING WIRING MAY NOT EXCEED BARRIER C_a . L_i OF TRANSMITTER PLUS INDUCTANCE OF INTERCONNECTING WIRING MAY NOT EXCEED BARRIER L_a .
2. CONTROL ROOM EQUIPMENT SHALL NOT USE OR GENERATE OVER 250 VOLTS.
3. INSTALL IN ACCORDANCE WITH THE NATIONAL ELECTRICAL CODE (NFPA 70)
4. FOR INTRINSICALLY SAFE CLASS II AND III, DIV 1, GP E, F AND G INSTALLATIONS WHERE CONDUIT IS NOT USED, INSTALL CABLE GLAND FITTING WHICH IS LISTED FOR CLASS II AND III HAZARDOUS (CLASSIFIED) LOCATIONS.
5. INSTALL INTRINSIC SAFETY BARRIER PER BARRIER MANUFACTURER'S INSTRUCTIONS.

THIS DRAWING NOT TO BE CHANGED WITHOUT FACTORY MUTUAL APPROVAL

7/23/96 MLS

1 EO-3872

TITLE CONTROL DRAWING FM APPROVED
SERIES 700 P9 ULS

BY *J Wig*
APPD *Jac*

DATE 7-18-96
DATE 7/24/96

DRAWING NO. 9065-135
SHEET 1 OF 1

REV 1

Control Drawing

DRAWING NO. 9065-124

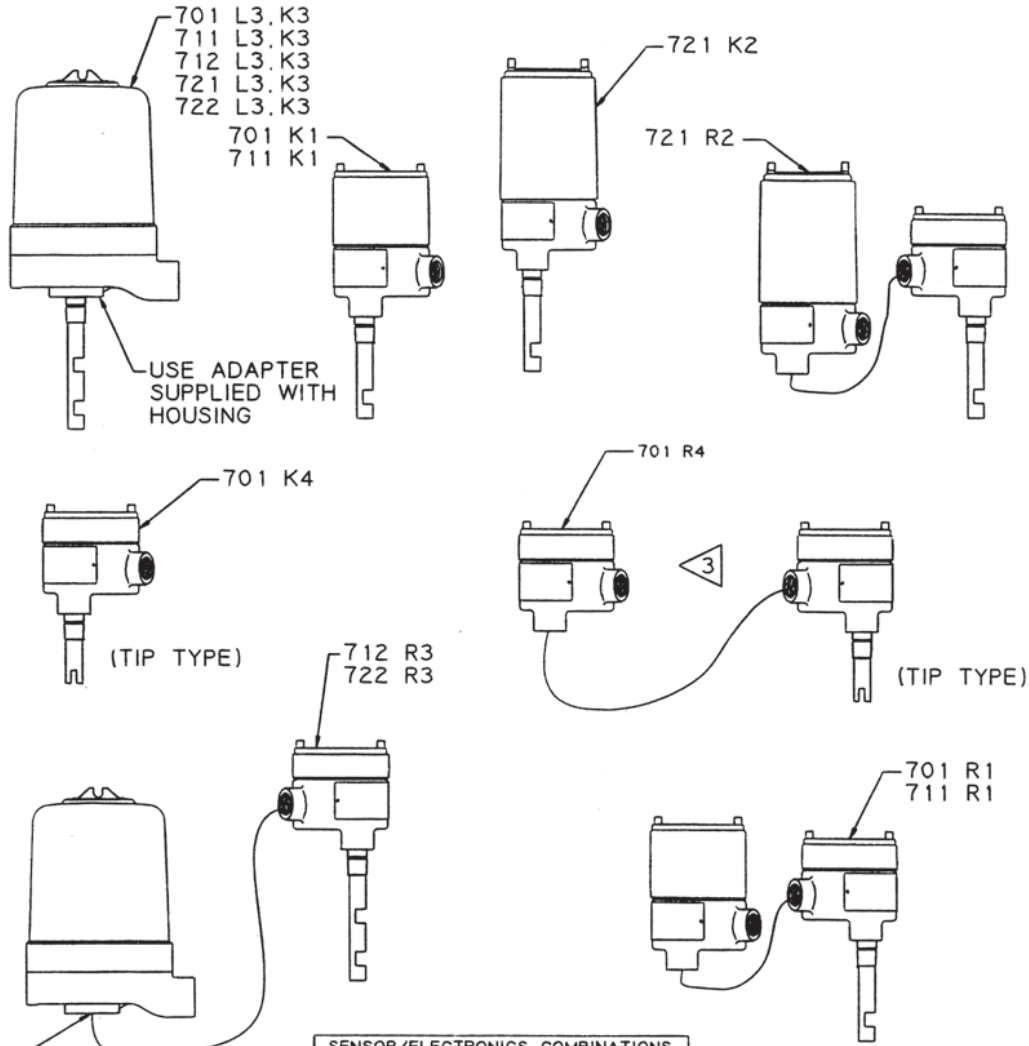

SENSOR/ELECTRONICS COMBINATIONS	
ELECTRONICS	SENSOR
701	371U
711	371N OR 371G
721	371N OR 371G
712	372N
722	372N

- NOTE:
1. ONLY THOSE SENSOR/ELECTRONICS COMBINATIONS LISTED ABOVE ARE VALID.
 2. SENSOR/ELECTRONICS COMBINATION IS CERTIFIED FOR THE LESSER HAZARDOUS LOCATION RATING OF THE SENSOR OR THE ELECTRONICS HOUSING. FOR EXAMPLE THE ASSEMBLY OF A GROUP B SENSOR WITH A GROUP C HOUSING IS CERTIFIED FOR GROUP C.
 3. WIRING SHALL BE INSTALLED IN COMPLIANCE WITH APPLICABLE CSA EXPLOSION PROOF STANDARDS FOR HAZARDOUS LOCATIONS.

THIS DRAWING NOT TO BE CHANGED WITHOUT CSA APPROVAL.

1 EO-3771 TAH 8/8/95 MLS 6/7/96 MSB
2 EO-4242 WDE 6/7/96 MSB

TITLE		BY	DATE	DRAWING NO.	REV
INSTALLATION DRAWING CSA PROBE/ELECTRONICS COMBINATIONS		WDE	6/7/96	9065-124	2
		APPD	DATE	SHEET	OF
		jae	6/7/96	1	1

Control Drawing

9065-136

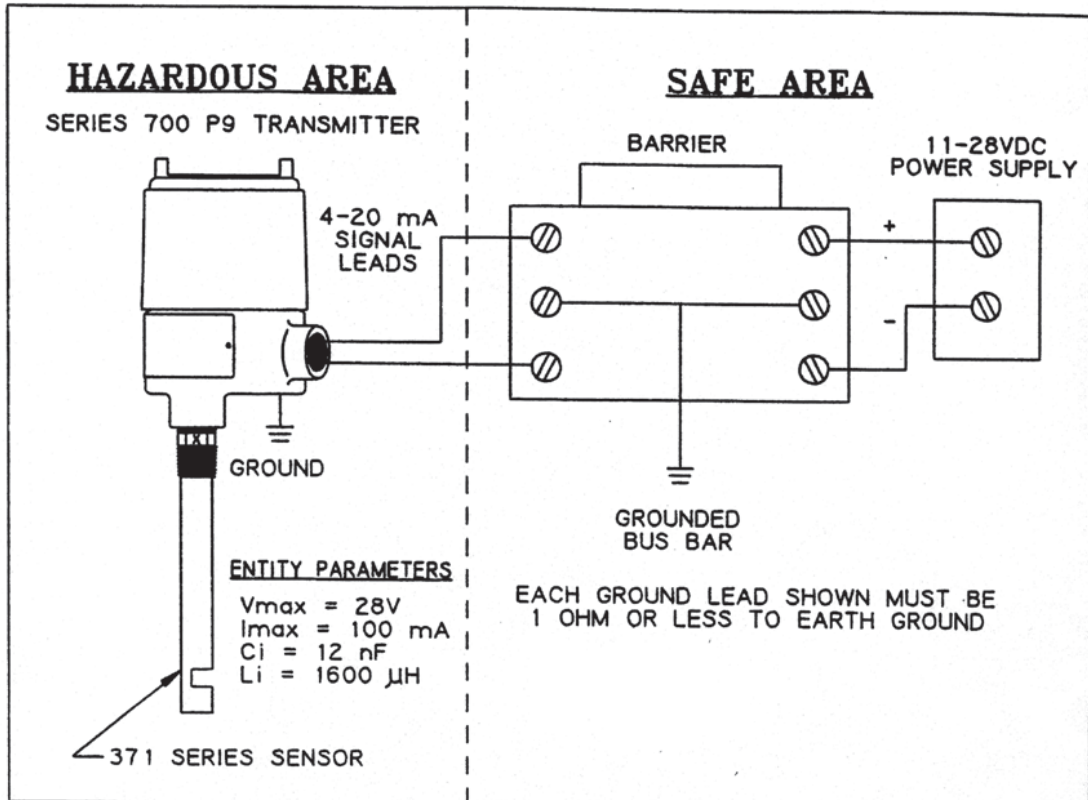

1. BARRIERS MUST BE INSTALLED IN ACCORDANCE WITH MANUFACTURERS INSTRUCTIONS.
2. BARRIER PARAMETERS MUST MEET THE FOLLOWING REQUIREMENTS:
 $V_{oc} \leq V_{max}$ $C_a \geq C_i + C_{Cable}$
 $I_{sc} \leq I_{max}$ $L_a \geq L_i + L_{Cable}$
3. MAXIMUM NON-HAZARDOUS AREA VOLTAGE MUST NOT EXCEED 250 V.
4. INSTALL IN ACCORDANCE WITH CANADIAN ELECTRICAL CODE, PART I.

Exia INTRINSICALLY SAFE/SECURITE INTRINSEQUE
 WARNING: SUBSTITUTION OF COMPONENTS MAY IMPAIR INTRINSIC SAFETY.
 ADVERTISSEMENT: LA SUBSTITUTION DE COMPOSANTS PEUT COMPROMETTRE LA SECURITE INTRINSEQUE

THIS DRAWING NOT TO BE CHANGED WITHOUT CSA APPROVAL.

1 EO-3872
 7-12-96
 MLS
 Gm16

TITLE	CONTROL DRAWING CSA APPROVED	BY	WJG	DATE	04-09-96	DRAWING NO.	9065-136	REV	1
	SERIES 700 P9 ULTRASONIC POINT LEVEL CONTROL	APPD	JAE	DATE	4/10/96	SHEET	1	OF	1



Printed in USA

sorinc.com

14685 West 105th Street, Lenexa, KS 66215 ■ 913-888-2630 ■ 800-676-6794 USA ■ Fax 913-888-0767

16/16 Registered Quality System to ISO 9001

Form 841 (08.13) ©SOR Inc.